

# THE 4LIFE SHED

~ 25 year guarantee ~

## SHED INSTRUCTIONS

### BASE KIT 1

**Apex/Reverse apex sheds with a single door & ridge beam for roof structure**

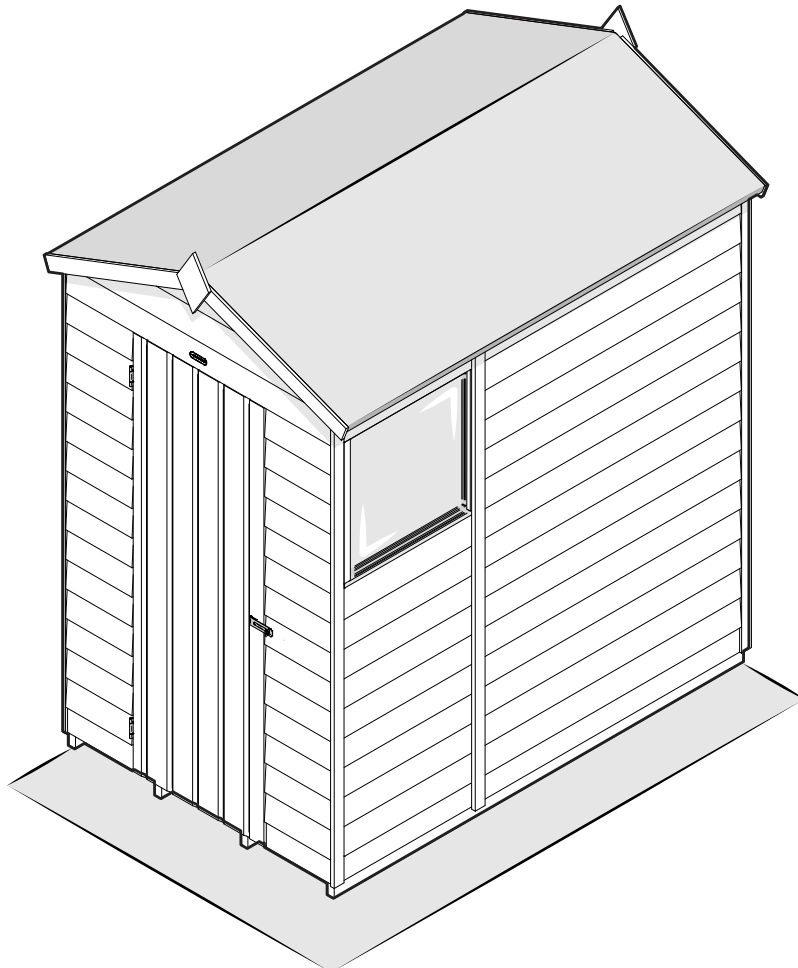

*Please note these instructions are generic as the construction for both shiplap and overlap sheds are the same. Any differences will be outlined in the steps.*

**Missing something or need more information?**

Call our aftersales team on  
0333 321 3142

**Visit our website for spare instructions and  
more information**

[www.forestgarden.co.uk](http://www.forestgarden.co.uk)

Forest Garden, Oak Drive, Hartlebury Trading Estate, Hartlebury, Worcestershire, DY10 4JB

EU Authorised Representative: Authorised Representative Service, 77 Camden Street Lower Dublin, D02 XE80, Ireland

# BEFORE YOU START.

Please read through this guide to prepare yourself before assembling your shed. We recommend that you **check all the components and fixings**. Your parts list can be found on your shed label.

All our sheds are constructed in the same way, they simply come with different components depending on the type of shed you have. We have sent you **generic fixing packs** and **generic loose item packs** to suit the shed range. You should expect there to be leftover fixings and loose items.

## BASE PREPARATION

It is vital that you build your new shed on a **solid, level base**. Timber or Plastic Shed Bases are ideal, as is solid concrete or concrete slabs.

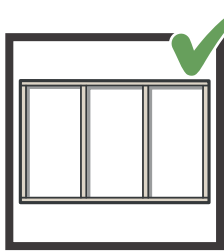

**Timber Base**

Self-constructed/  
Buy pre-made

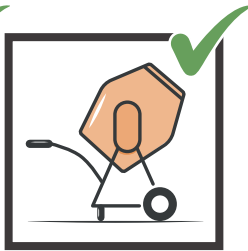

**Concrete**

Concrete surface/  
Concrete slabs



**Pro Shed Base**

Interlocking  
eco-friendly base

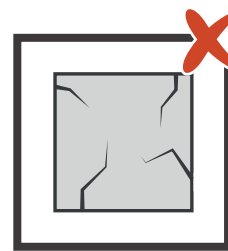

**Broken Slabs/Gaps**

Uneven slab sizes  
with no cement



**Loose Soil**

A base of soil or  
grass only

If you have an existing base and think it is suitable for your new shed to be sited on, it is important you check that it is level and **does not deviate by any more than 15mm** from edge to edge. If this is not the case the building will twist, causing gaps to appear in the sections and the roof, doors, and windows to misalign.

There is more information on base preparation on our website [www.forestgarden.co.uk](http://www.forestgarden.co.uk)

## TOOLS REQUIRED

We recommend using the following tools (**not supplied**):

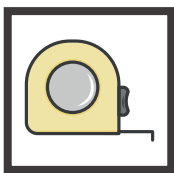

**Tape Measure**

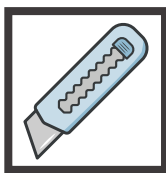

**Sharp Knife &  
Scissors**



**PZ2 Pozidriv &  
Screwdriver**

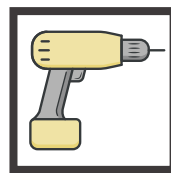

**Drill & 2-6mm  
Drill Bits**



**Hammer/  
Rubber Mallet**

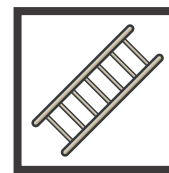

**Fit For Purpose  
Ladder**

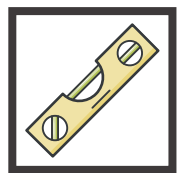

**Spirit Level**

We recommend getting everything aligned properly before screwing together and that the **screw holes are pre-drilled** at this stage to **avoid splitting the timber**. We do not provide pre-drilled holes due to the nature of expanding and shrinking timber, which can cause pre-drilled holes to misalign.



### IMPORTANT

Assembly requires 2+ adults.



### REMINDER

Always pre-drill before screwing.

**PLEASE KEEP PLASTIC BAGS AND SMALL PARTS AWAY FROM BABIES AND CHILDREN. TO AVOID DANGER OF SUFFOCATION, PLEASE KEEP THE PROTECTIVE FILM AWAY FROM BABIES AND CHILDREN. CHECK AND TIGHTEN ALL THE FIXINGS APPLIED TO THIS PRODUCT ON A REGULAR BASIS.**

# CARE & ATTENTION

To help you get the most out of our products it is useful to know a little more about the properties of timber, what is normal and how your shed may behave as the seasons change. Wood is an extremely durable material for construction but as a natural product when used outdoors it is susceptible to changes in the environment.

## THINGS THAT YOU MIGHT SEE IN YOUR PRODUCT

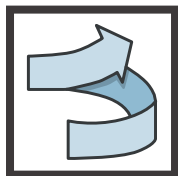

### Movement, Twisting & Warping

Wood contains a natural level of moisture so decreasing humidity levels in the surrounding air may cause panels to change their shape as the porous fibres shrink. This can be exaggerated during prolonged periods of dry weather. Movement and gaps in timber products are normal, in most cases the wood will revert to its original form once the high temperatures subside and there is more moisture content in the air. Similarly, in the winter months, the opposite may occur with wood swelling.



### Expansion, Contraction, Splits & Cracks

All timber will expand and contract according to its environment. As a result of this expansion and contraction, it is very common to see splits and cracks developing in the wood. Splits are common during the spring and summer months as the wood begins to dry out. The outer surface dries first and contracts, contracting over a still expanded core of the wood. The result of this is that splits and cracks appear along the grain of wood. These splits are not a fault and do not affect the structural integrity of a product.



### Mould & Blue Stain

Mould is a surface-dwelling fungus that feeds on the nutrients and debris contained in the surface cells of timber. The most common problems associated with mould are discoloured timber and an increase in permeability of the timber. Blue stain is part of the same family but penetrates deeper into the surface layers of the timber. It stains the timber a dark blue, whereas mould is usually black. These do not cause the timber to rot. Keep the building well ventilated to avoid mould.

### Advice On Felt Handling & Usage

Roofing felt is flexible at temperatures above 5°C. In cold temperatures extra care must be taken when handling and installing to prevent cracking and damage to the felt. The felt should not be rolled, folded, or used in temperatures lower than 5°C. In cold temperatures the felt should be stored above 10°C (indoors) for 24 hours prior to use. Felt must be lifted, not dragged, and should be stored on its end on a dry surface. **Please contact our aftersales team if you are missing your felt.**

## 8 TOP TIPS TO ENSURE YOUR SHED IS FULLY WATERPROOF

- 1 POSITION YOUR SHED IN THE BEST LOCATION IN YOUR GARDEN**  
Avoid areas where water pools and which are constantly wet. Position away from trees and cut back any overhanging foliage which can cause moisture to be trapped against the walls and debris to collect on the roof.
- 2 RAISE YOUR SHED OFF THE GROUND**  
Ideally, any concrete base should be the same footprint as the shed to allow surface water to run off without pooling. A timber base can also be used. Raise your shed 50mm above ground level.
- 3 SEAL THE BEARERS**  
If using a wooden base, we recommend treating it with a treatment containing wax or oil. Also coat the bearers that meet the ground to prevent moisture rising.
- 4 USE AN END GRAIN PROTECTOR**  
To protect the corners and panel joins, an end grain protector can be applied.
- 5 SEAL THE PANELS & WINDOWS**  
Use a flexible silicone sealant around windows to prevent water ingress. This can also be used where two sections of the shed join together. Apply internally.
- 6 CONSIDER ADDING GUTTERS**  
Adding guttering around the fascia of the shed will redirect rainwater away from the shed's foundation.
- 7 KEEP VENTILATED**  
Good airflow around the perimeter of the shed and regular ventilation inside the shed will help prevent mould and mildew.
- 8 CONSIDER A WATER SEALANT**  
You may want to consider painting your shed with a water sealant at least once a year. This will help reduce the risk of water ingress. We would recommend using 'Bostik Cementone Water Seal' of which can be purchased from multiple DIY stores.

# HEALTH & SAFETY

We strongly recommend that PPE (Personal Protective Equipment) is used throughout your build to ensure you are protected from any potential health and safety risks. **Do not exempt yourself from wearing PPE.**



Cut-Resistant  
Gloves

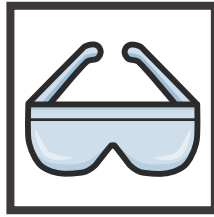

Protective Glasses



Protective Boots

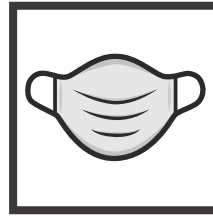

Protective Mask



Working At  
Height

## THE ROOF OF THIS BUILDING IS NOT A LOAD BEARING STRUCTURE.

The components provided may be heavy. Please lift with caution and with a minimum of 2 people. Please carefully unpack your shed and loose components as they may have moved during transportation.

# TREATMENT INFORMATION

The treatment applied to your shed is to ensure longevity and protection against fungal decay and rot. This may leave colour variations, but these will even out as the moisture content stabilises.

Pressure Treatment
Pressure treatment is to provide protection against rot
Pressure treated sheds do not need to be re-treated every year
25 year guarantee

Use the 'waterproofing top tips' to increase the longevity of your shed. See our website for more information at [www.forestgarden.co.uk /guide-to-our-products/](http://www.forestgarden.co.uk/guide-to-our-products/)

### Treated timber contains biocidal products for control of wood destroying organisms.

**Active Ingredients** - Basic Copper Carbonate, DDA Carbonate, DDA Chloride.

- Wear gloves when handling.
- Avoid inhalation of sawdust.
- Do not use in contact with drinking water or food.
- Do not use for animal bedding or in fish ponds.
- Dispose of treated wood responsibly.
- Treated products cannot be recycled as the wood is no longer in its original virgin state.
- Once the treatment has dried there is no risk of toxic contamination. The risk would come from the treatment before it is added to our products.

# DISCLAIMER

## Check you have all your parts prior to assembly.

Timber is a natural material of which will shrink and swell because of varying moisture content.

Assembly of damaged parts may be deemed to be acceptance, and this may affect the remedies you are entitled to.

If the product is not constructed in accordance with the instructions, or is altered in anyway (e.g. painted), the manufacturer cannot be held liable for any resulting damage.

If you are organising a third party to install your shed, it is best not to schedule this immediately on receipt of your order, to give you time to check your delivery.

# IDENTIFY YOUR CHOSEN SHED

From the **floor plans** below, identify your shed based on the **width, depth** and **roof type** provided. You will need this to identify the side panel positions before assembling your shed. **Use the key as a guide.**

## KEY

- (A)** 1ft Panel (295 x 1831mm)
- (B)** 2ft Panel (590 x 1831mm)  
(With & without windows)
- (C)** 3ft Panel (885 x 1831mm)  
(With & without windows)
- (D)** 4ft Panel (1180 x 1831mm)  
(With & without windows)
- (E)** 3ft Door Panel (885 x 1831mm)

## PLEASE NOTE

Same size panels are interchangeable. Hinge your single door onto either side.

## INFILL PANELS

Most of the single door sheds will have 'Infill Panels' of which are secured to the top of the Side Panels. They will be the same width as door opening beneath. They are used to finish the single door panel. Lay these out with your Side Panels around your shed floor(s) for preparation. **Follow the assembly steps for more details.**

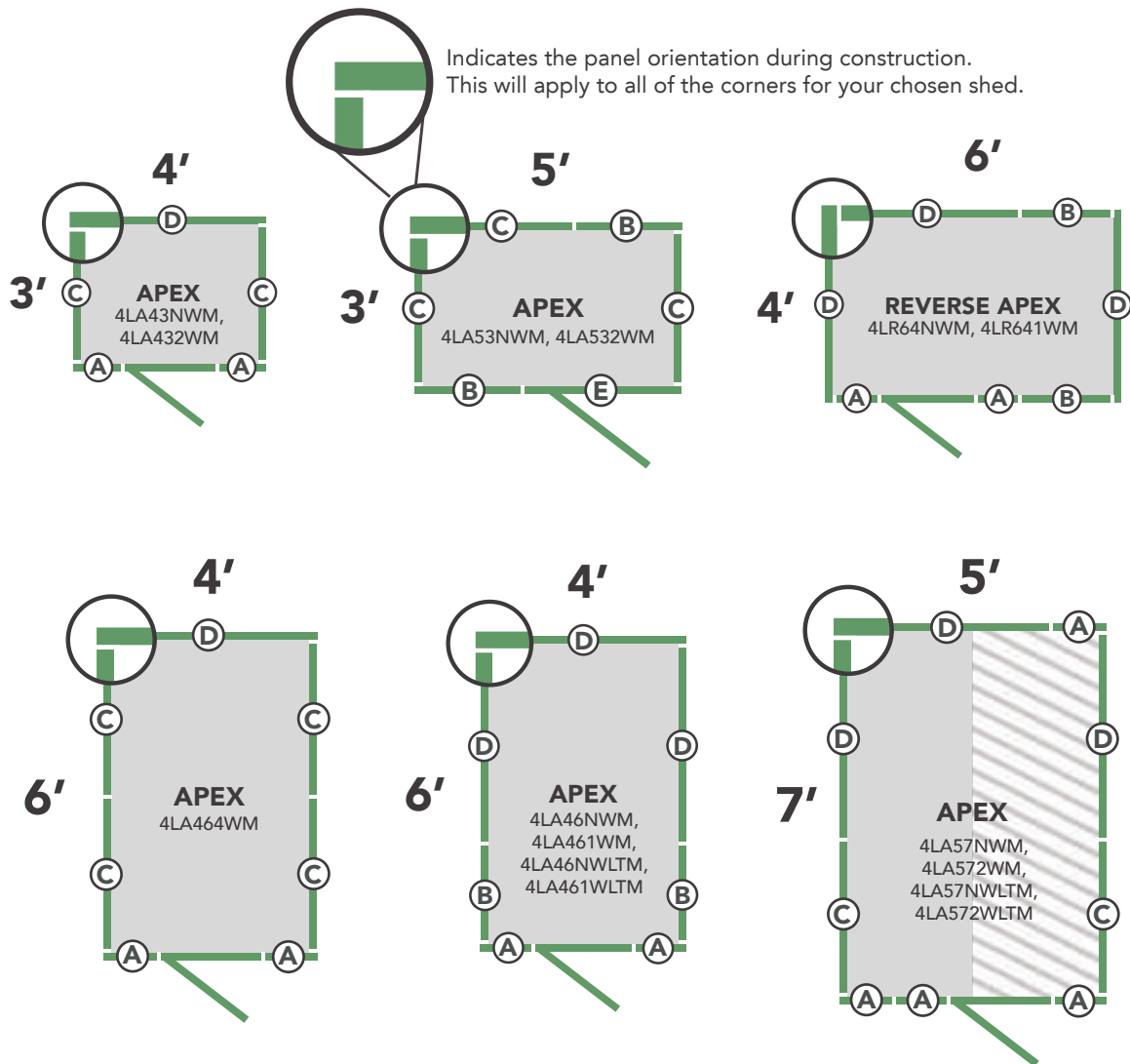

## FIXING PACKS

We have provided **several fixing packs** for your build. Each fixing pack will contain fixings for each step of the assembly.

These fixing packs are generic, to suit the modular shed range. Visuals in each of the **steps are for reference only** and may slightly vary depending on the shed you have chosen. Any major differences will be outlined in the steps. We have designed them to be as simple as possible to follow, but **if you have any issues, please contact our aftersales team.** **Check your parts list prior to assembly,** of which can be found on your shed label.

# FLOOR ASSEMBLY

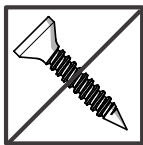

## THERE ARE NO FIXINGS FOR THIS SECTION.

Look through the different visuals and follow the step that suits your chosen shed.

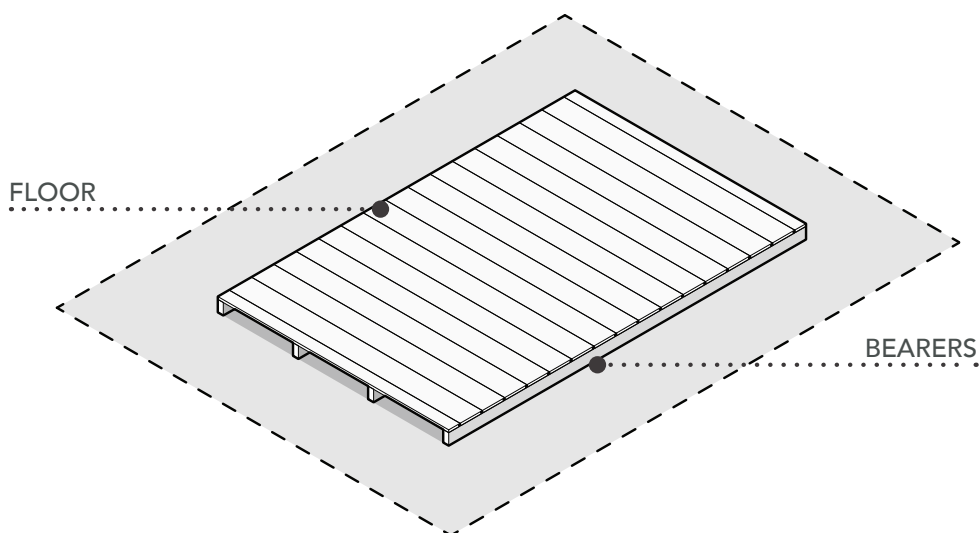
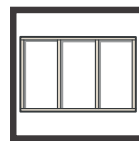
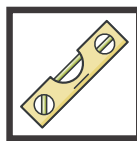

Before assembly, **your Floor must be firm and level** to ensure the shed lines up and is assembled properly. We recommend that there should be **access to all sides of your shed for assembly and any maintenance**.

## STEP 1: POSITION FLOOR(S)

Due to the health and safety concerns of the Floor weights, we **do not** advise to secure the floors together. If you wish to secure the floors together, you do so at your own risk.

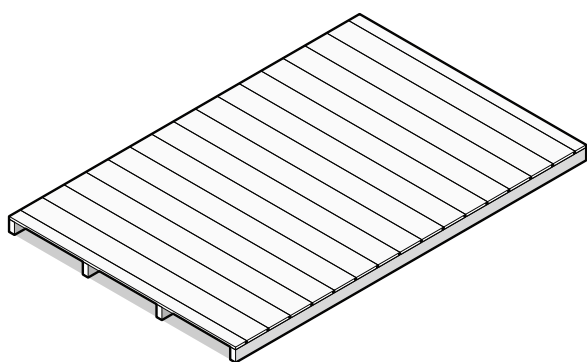

### SINGLE FLOOR

Position the Floor in your desired location.

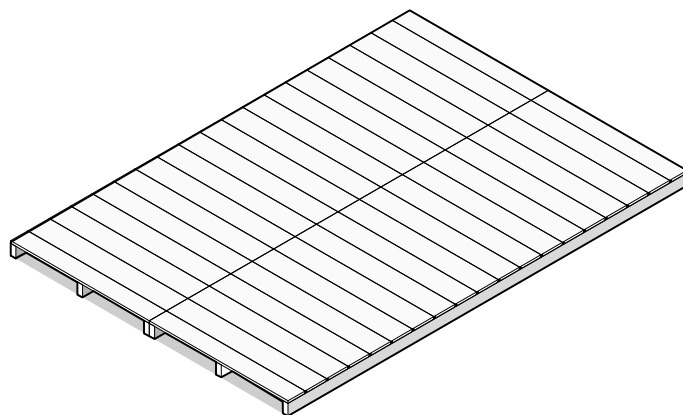

### DOUBLE FLOOR

Position the Floors in your desired location. **Butt the Floor bearers together** and ensure they are flush on each side. The **bearers** will be butted together **along their side face** as shown above.

# WINDOW ASSEMBLY

(PLEASE SKIP THIS SECTION IF YOUR SHED HAS NO WINDOWS)

## FIXING PACK CONTAINS:

FIXING PACK CODE: 4LIFEWINFP

You may receive more than one of the same fixing pack to provide enough fixings for the sheds with more windows.



3.5 x 30mm Screws  
QTY: 6



3.5 x 25mm Screws  
QTY: 38

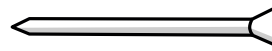

1.6 x 30mm Nails  
QTY: 8

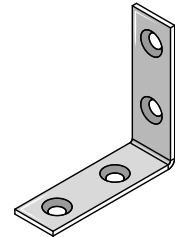

L-Brackets (50mm)  
QTY: 8

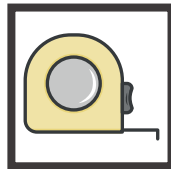
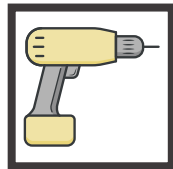

## STEP 1: WINDOW SILL ASSEMBLY

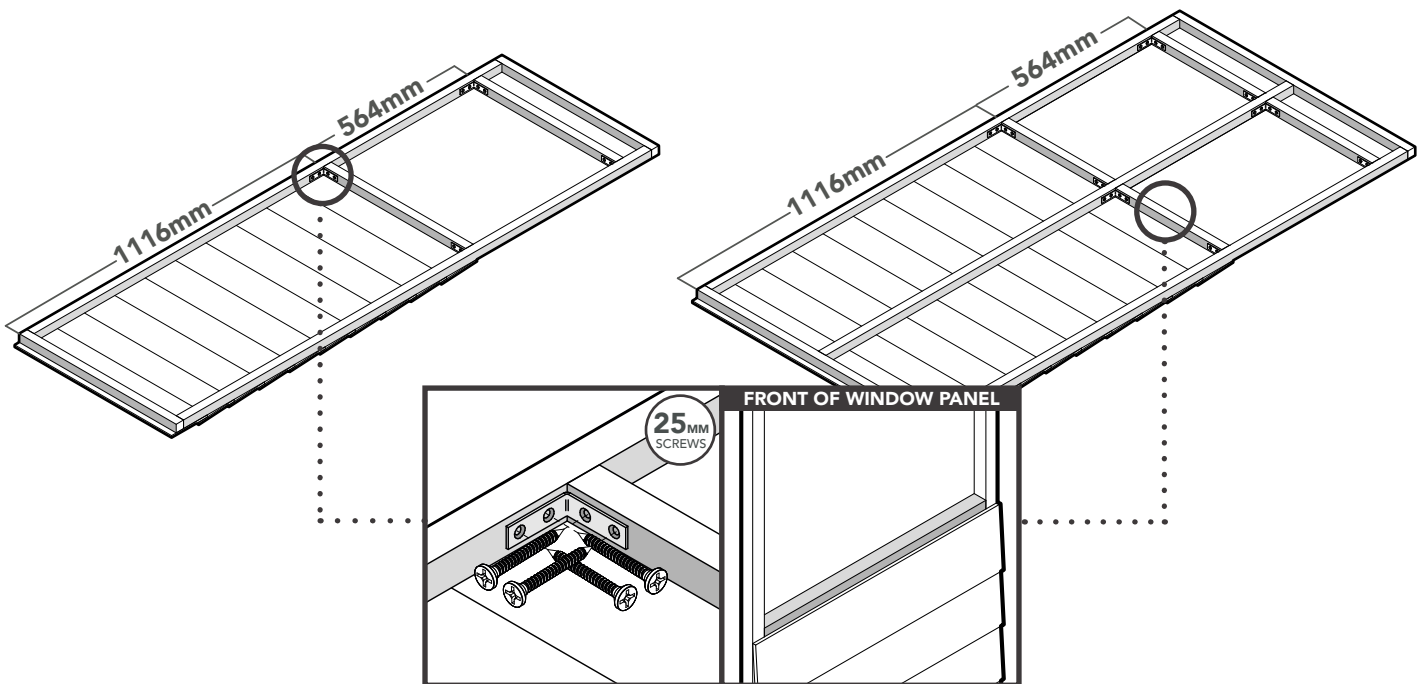

### WINDOW SILLS

Position and secure the Window Sills to the Window Panel(s) using the measurements provided. Use 2 x L-Brackets per Window Sill. Ensure the bottom Window sill overhangs the overlap board underneath the window opening as shown above.

2ft Window panel window sill size (28x28x534mm), 3ft Window panel window sill size (28x28x400mm),  
4ft Window panel window sill size (28x28x548mm)

## STEP 2: WINDOW POSITIONING

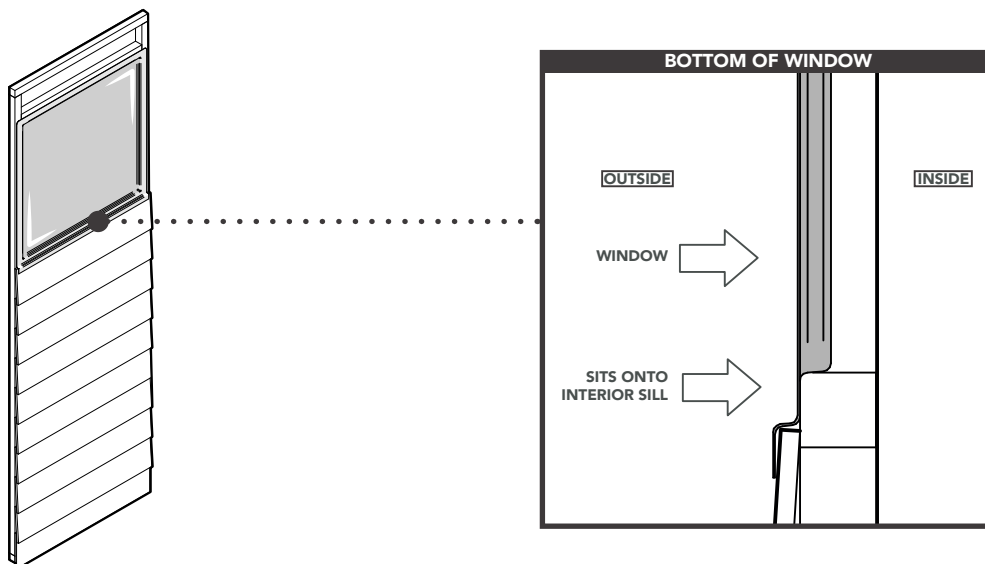

### WINDOW(S)

Position your Window(s) into the window opening as shown above. Ensure the bottom and top are resting on the Window Sills

## STEP 3: SECURE WINDOW(S)

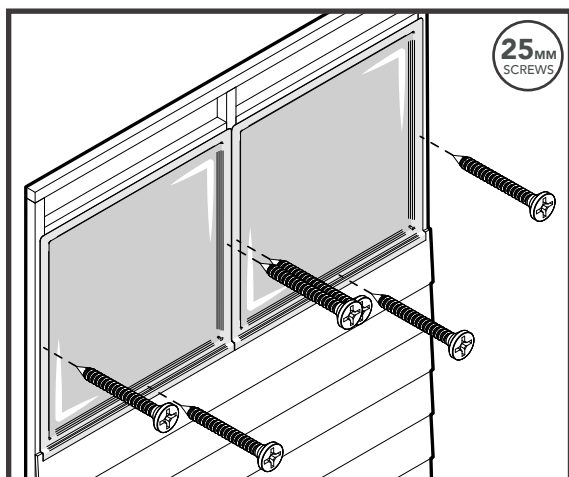
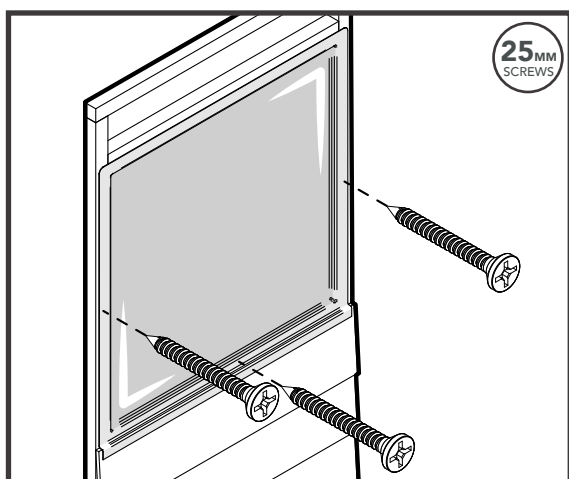

### WINDOW(S)

Secure the Window(s) to the framework using 1 x 25mm screw on both sides and the bottom.



## STEP 4: SECURING THE TOP BOARD

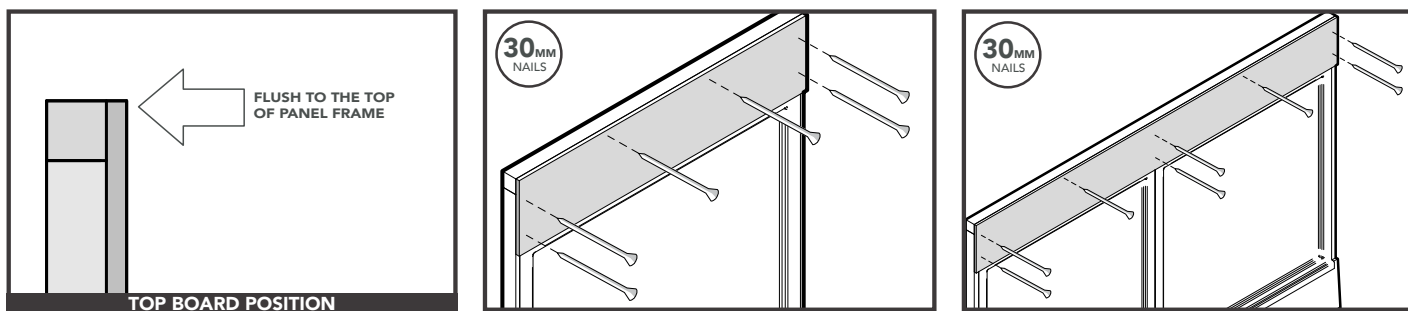

### SECURE TOP BOARD

Position the Top Board to the top of the Window Panel framework, ensuring it is flush as shown above. Secure the Top Board to the window panel framework behind with the nails provided. ensure the top board overlaps the top of the window

## STEP 5: WINDOW COVER STRIPS

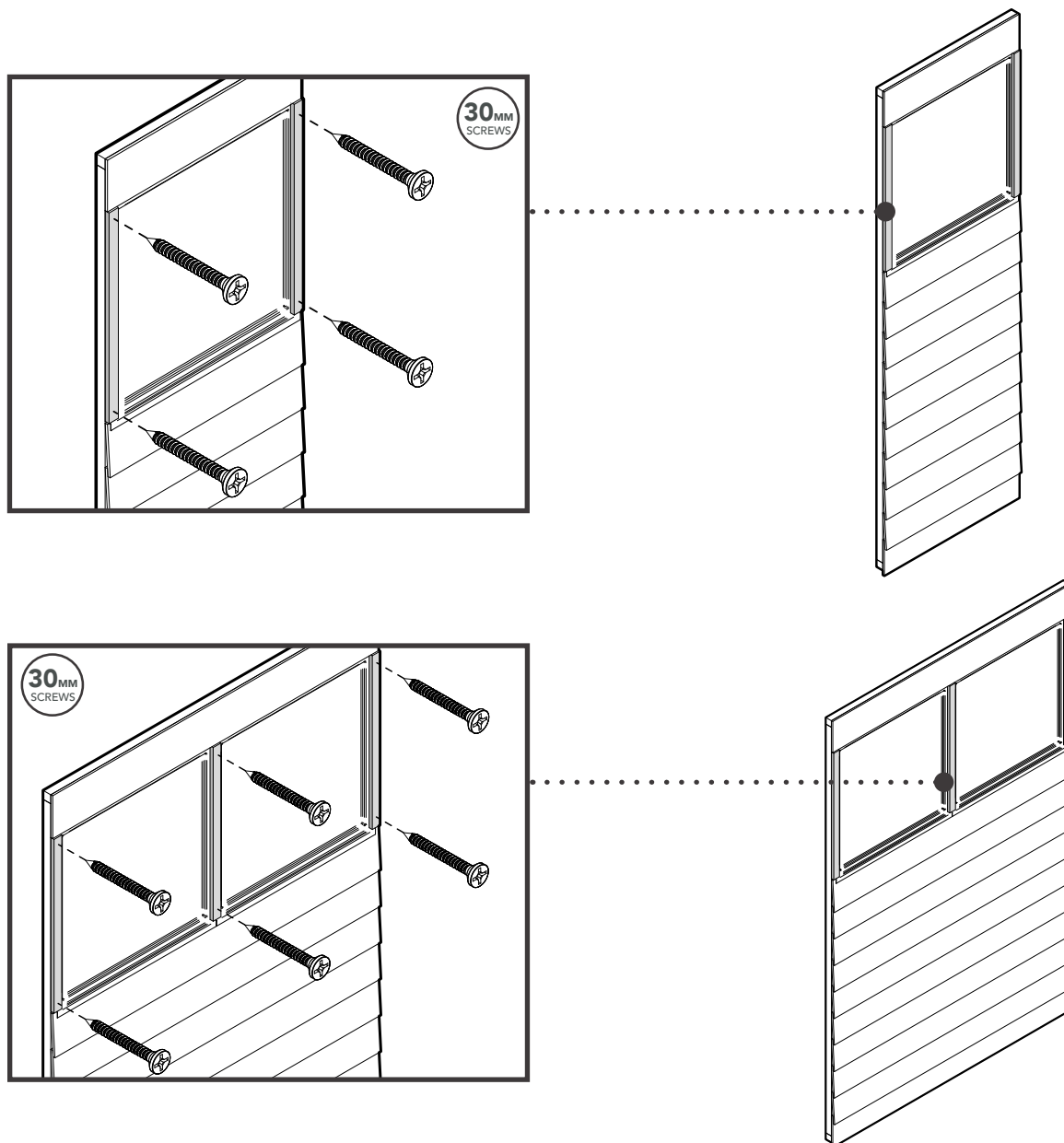

### WINDOW STRIPS

Position and secure the Window Strips to the framework using 30mm screws.

# SIDE PANEL ASSEMBLY

## FIXING PACK CONTAINS:

FIXING PACK CODE: SHEDPANELSFP



5 x 60mm Screws  
QTY: 3



4 x 50mm Screws  
QTY: 52



4 x 40mm Screws  
QTY: 2

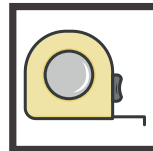
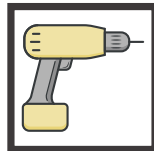
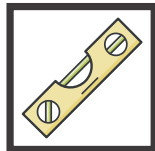

## STEP 1: SIDE PANEL ASSEMBLY

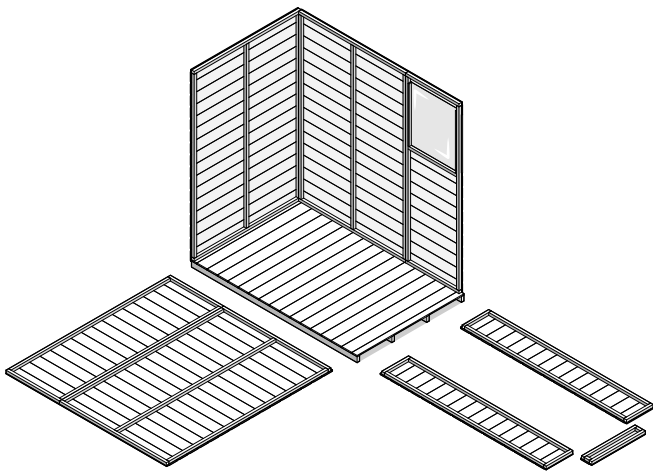

### LAY OUT YOUR PANELS

Lay out the panels around your shed Floor(s) to your desired panel configuration. Use your floor plan to confirm panel positions.

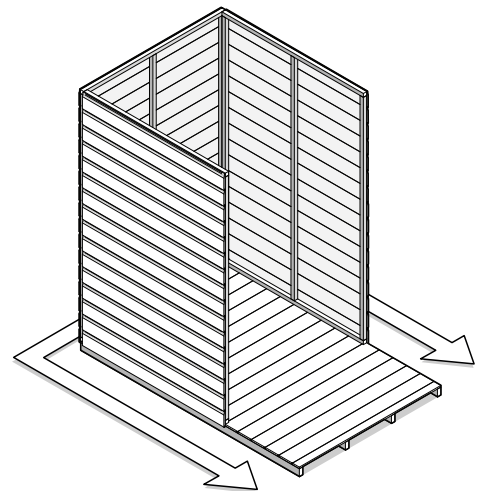

### WORK FROM BACK TO FRONT

We recommend starting from the back corner, and working your way to the front for assembly.

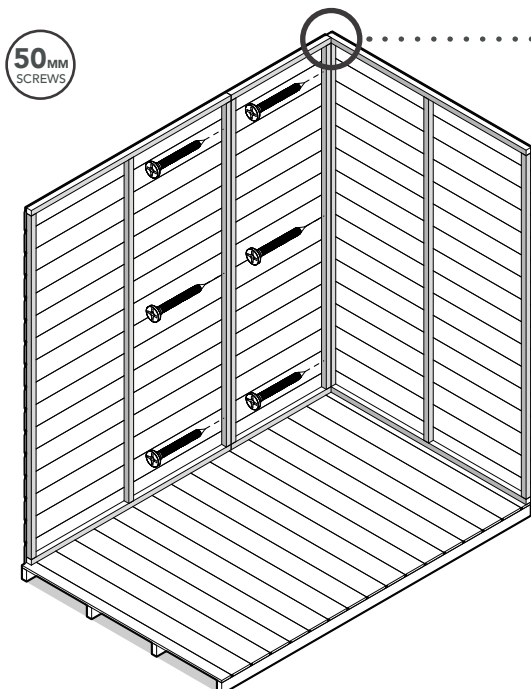

50MM  
SCREWS

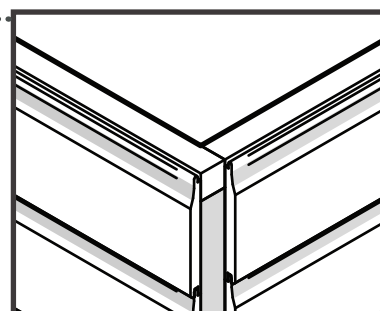

### EXTERNAL PANEL CORNERS

Ensure the corner panels are flush to the framework, as space next to the boards is for the Cover Strip to sit into.

### SECURE PANELS TOGETHER

Use your floor plan to confirm the corner panel positions. Position and secure the Side Panels together. Ensure the bottom batten on the Side Panels sit on the Floor and the bottom board is up against the Floor edge.

## STEP 2: SECURE SIDE PANELS TO FLOOR(S)

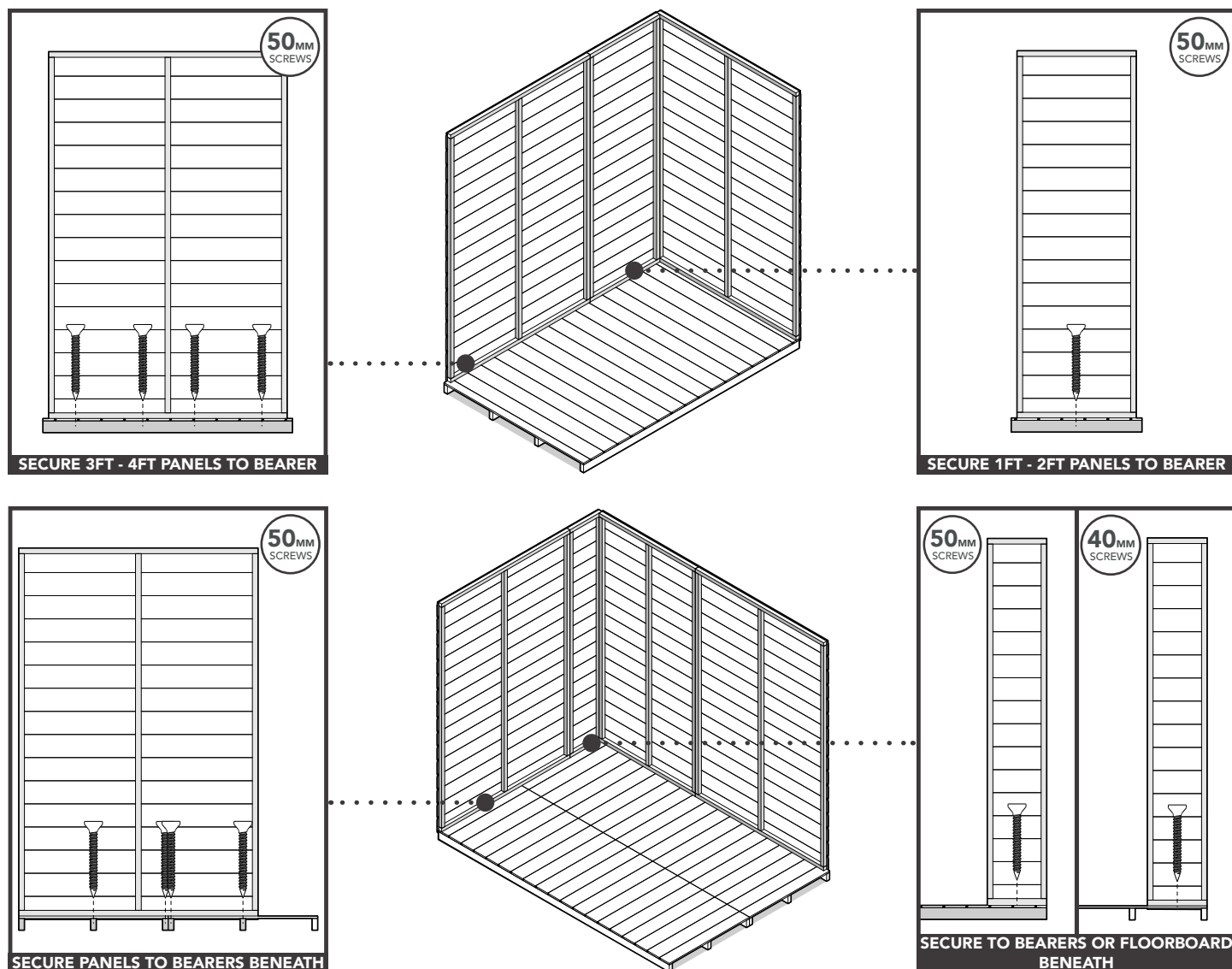

### SECURE TO FLOOR BEARERS/FLOORBOARD BENEATH

Secure the Side Panels to the Floor(s) by **screwing into the floor bearers beneath** (50mm screws).  
**Secure the Side Panels to the floorboards** if there are no bearers beneath (40mm screws).

## STEP 3: SECURE DOOR PANEL TO FLOOR

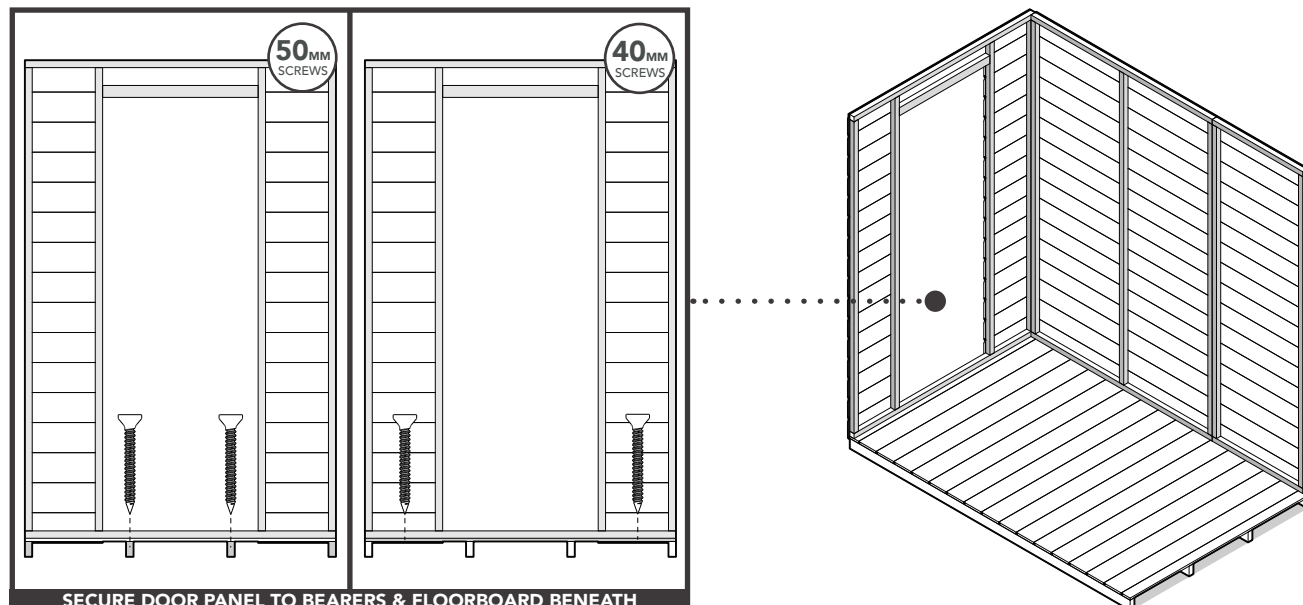

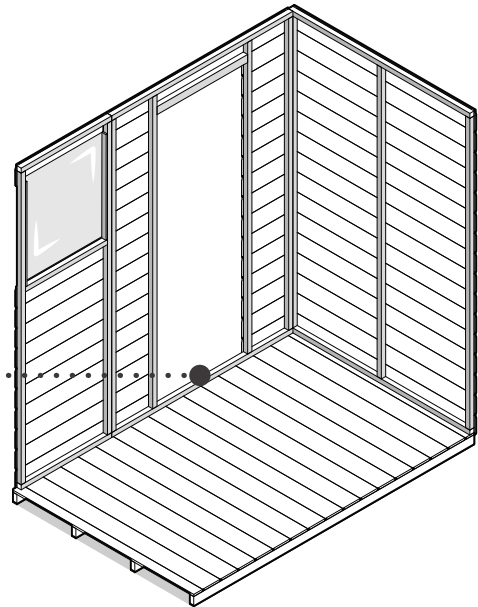

### SECURE TO FLOOR BEARERS/FLOORBOARD BENEATH

Secure the Door Panel to the Floor by **screwing into the floor bearers beneath** (50mm screws).  
**Secure the Door Panel to the floorboards** if there are no bearers beneath (40mm screws).

## STEP 4: SINGLE DOOR INFILL PANELS

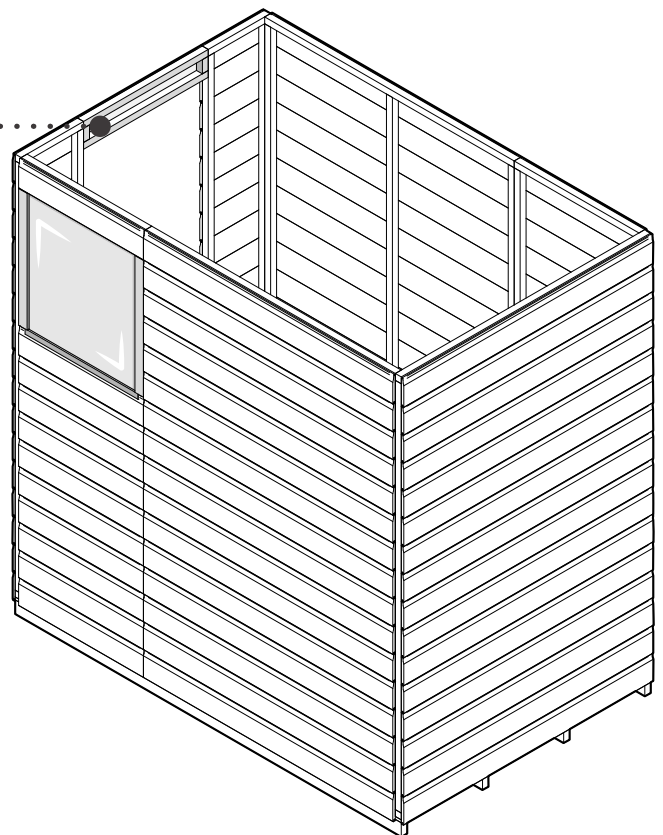
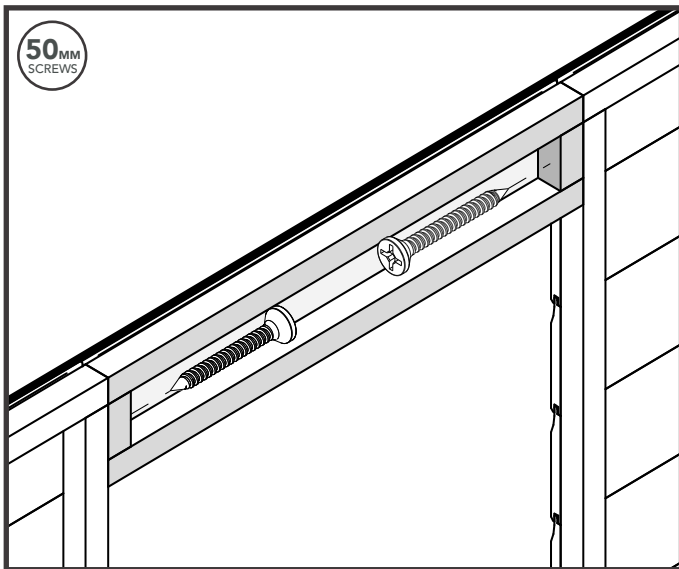

### SINGLE DOOR INFILL PANELS

Position the Single Door Infill Panel into the door opening. Secure to the panels on either side.

# APEX SECTION ASSEMBLY

## FIXING PACK CONTAINS:

FIXING PACK CODE: SHEDGABLEFP



4 x 50mm Screws  
QTY: 8

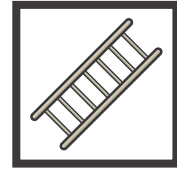
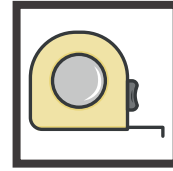
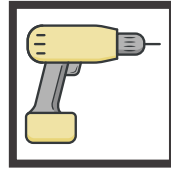

## STEP 1: APEX SECTION ASSEMBLY

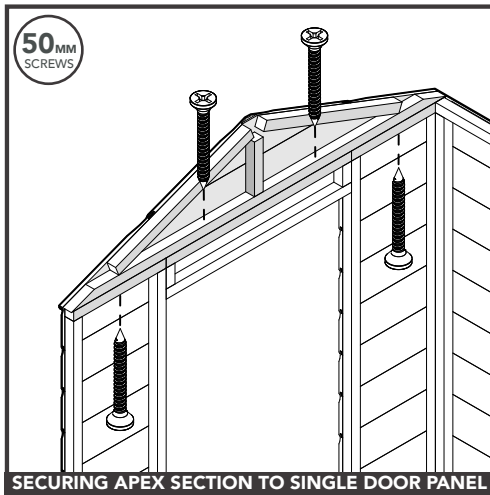

APEX SHEDS

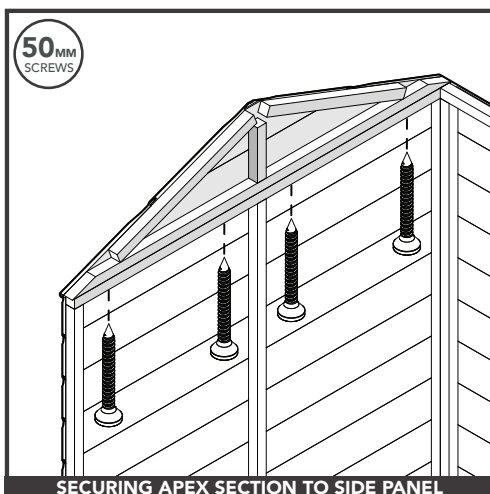
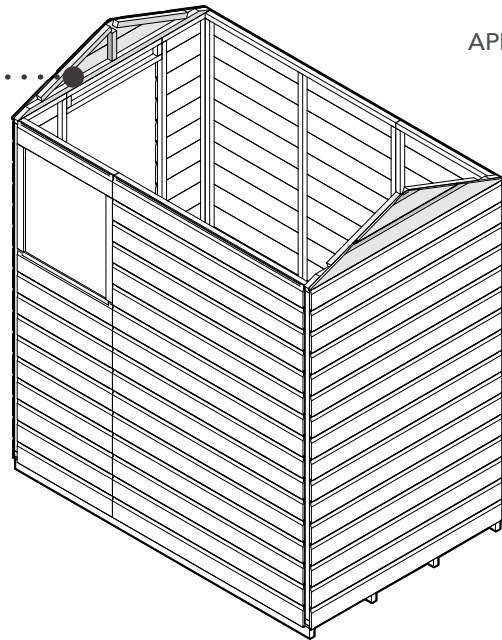

REVERSE APEX SHEDS

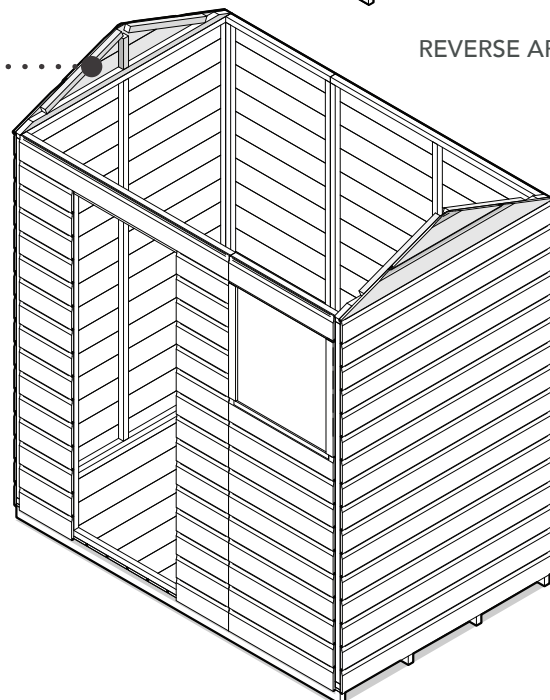

### APEX SECTIONS

Position and secure the Apex Sections to the Side Panels. For an apex shed, secure to the front and back. For a reverse apex shed, secure to the sides.

# COVER & DOOR STRIPS

## FIXING PACK CONTAINS:

FIXING PACK CODE: SHEDSTRIPSP



3.5 x 30mm Screws  
QTY: 33

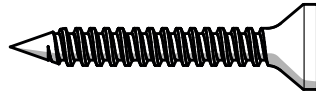

4 x 50mm Screws  
QTY: 4

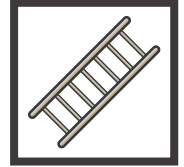
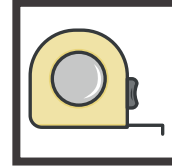
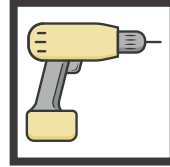

## STEP 1: DOOR BATTENS

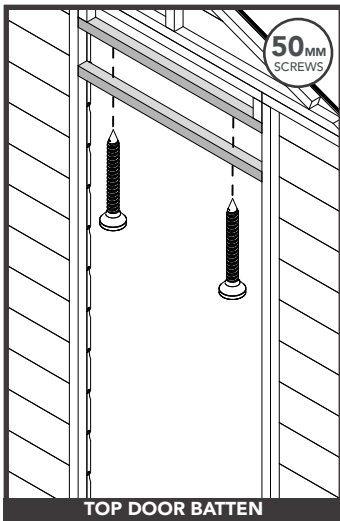

TOP DOOR BATTEN

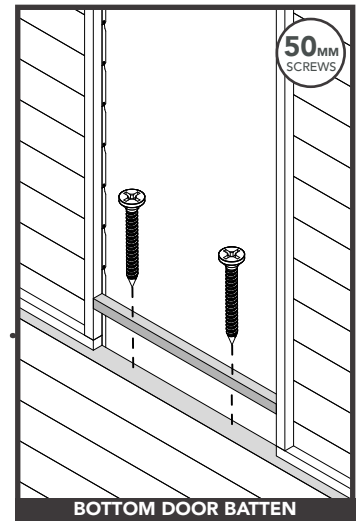
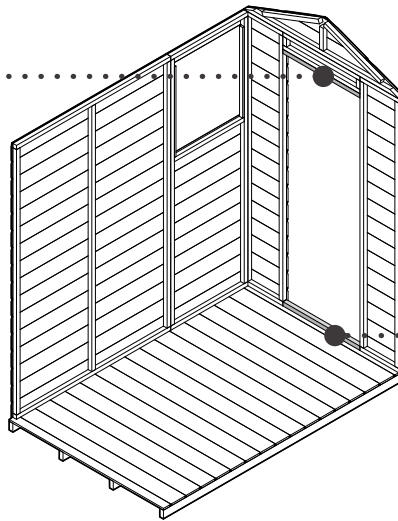

BOTTOM DOOR BATTEN

### DOOR BATTENS

Secure the Door Battens to the Top and Bottom of the door frame. Ensure they are flush to the Panel framework and they are screwed in to the bearers beneath.

Door Batten size (28x28x590mm)

## STEP 2: DOOR STRIPS

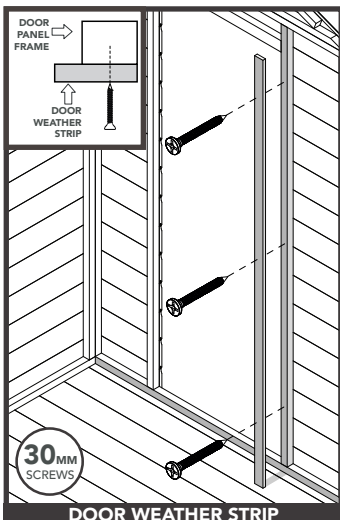

DOOR WEATHER STRIP

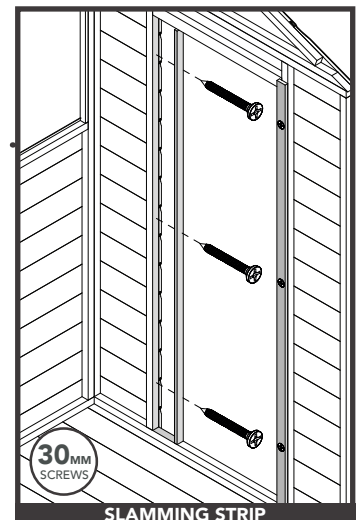
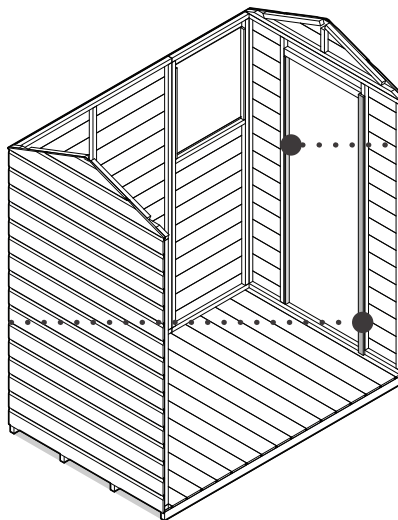

SLAMMING STRIP

### DOOR WEATHER STRIP

Secure the Door Weather Strip to the side you want the hinges. Ensure it is flush to the Floor and against the panels framework. Ensure there is approximately 10mm overhang into the door opening.

Door weather strip size (38x12x1710mm)

### SLAMMING STRIP

Secure the Slamming Strip, to the Panel framework. This will be on the opposite side of the hinges.

Slamming strip size (28x12x1637mm)

## STEP 3: COVER STRIPS

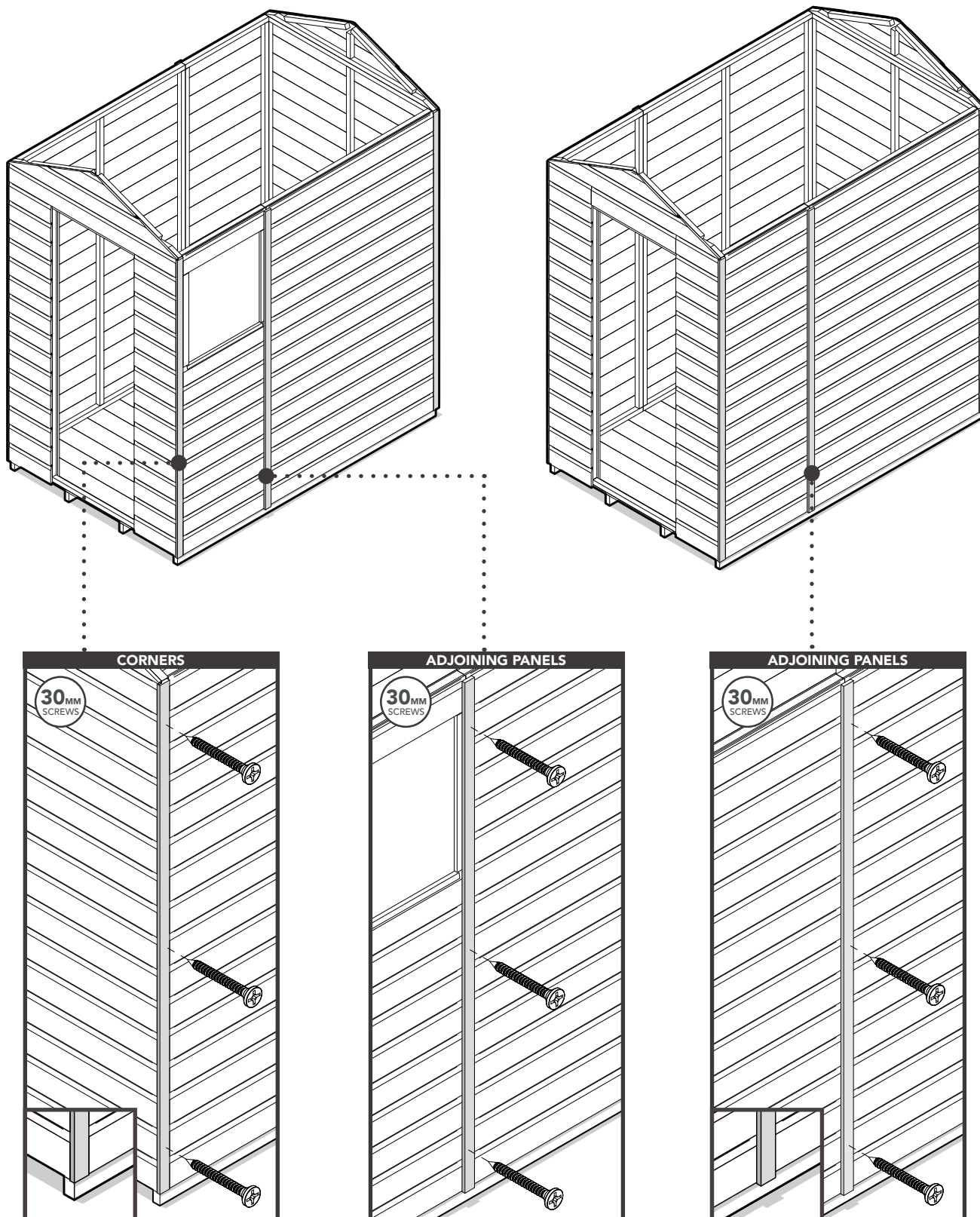

### COVER STRIPS

Secure the Cover Strips to the corners and adjoining panels. Ensure they are flush to the bottom edge of the panels. Make sure to secure the Cover Strips to the framework behind and not into the joints of the panels.

Cover strips size (1823mm)

# RIDGE BEAM ASSEMBLY

## FIXING PACK CONTAINS:

FIXING PACK CODE: SHEDRIDGEFP

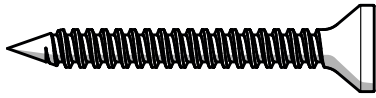

5 x 70mm Screws  
QTY: 2

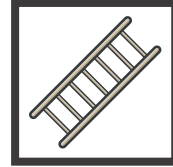
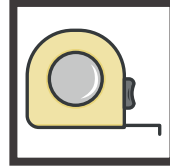
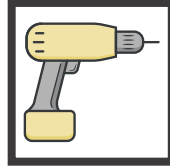

## STEP 1: RIDGE BEAM ASSEMBLY

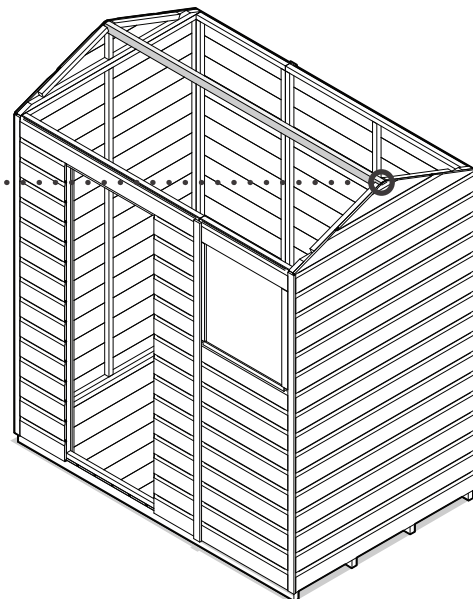
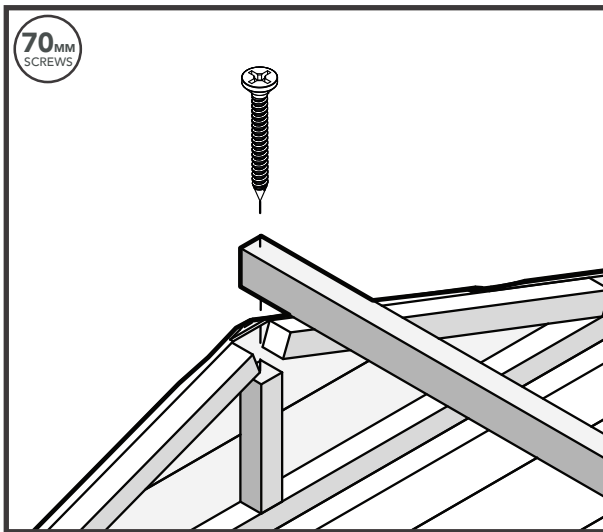
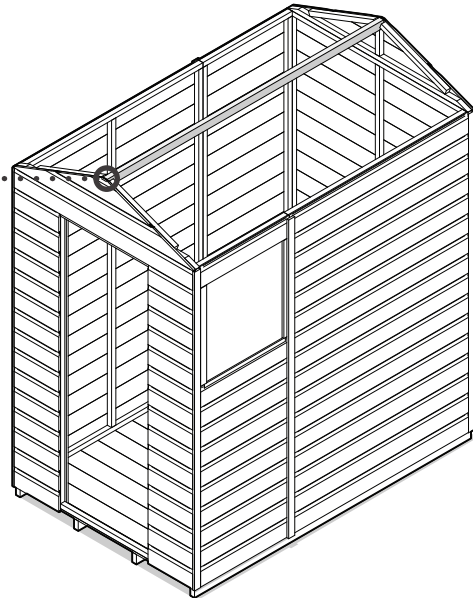
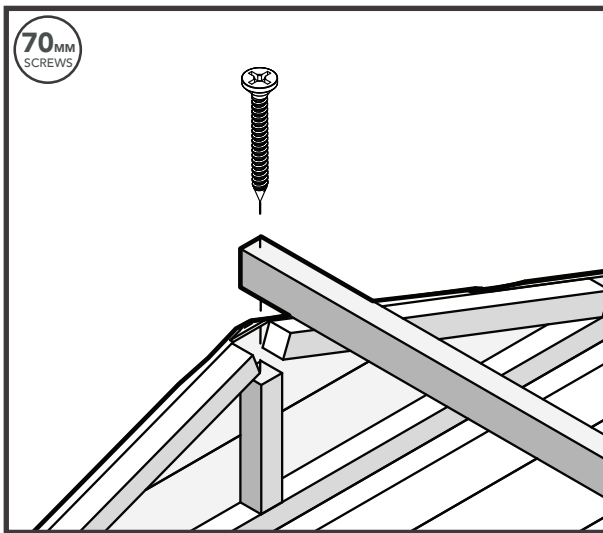

### RIDGE BEAM

Slot the Ridge Beam into the Apex Sections. Secure each end with 1 x 70mm screw into the apex framework beneath.



# OSB ROOF SHEET & FELT

## FIXING PACK CONTAINS:

FIXING PACK CODE: OSBSHEDROOFFP



3.5 x 30mm Screws  
QTY: 60

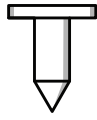

Felt Tacks  
QTY: 145

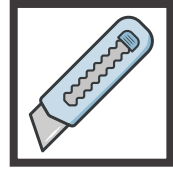
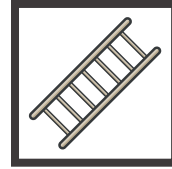
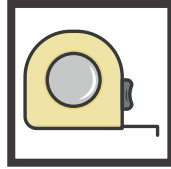
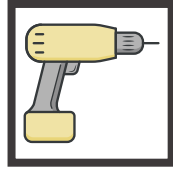

## STEP 1: OSB ROOF SHEETS & ROOF STRIPS

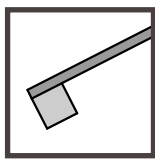

30MM  
SCREWS

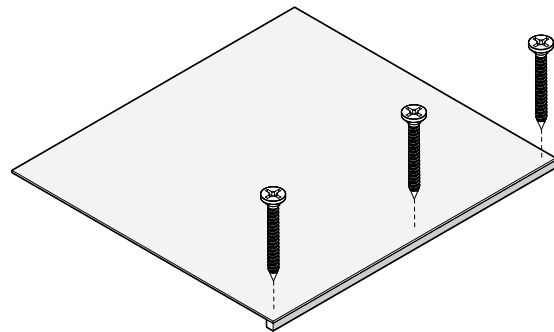
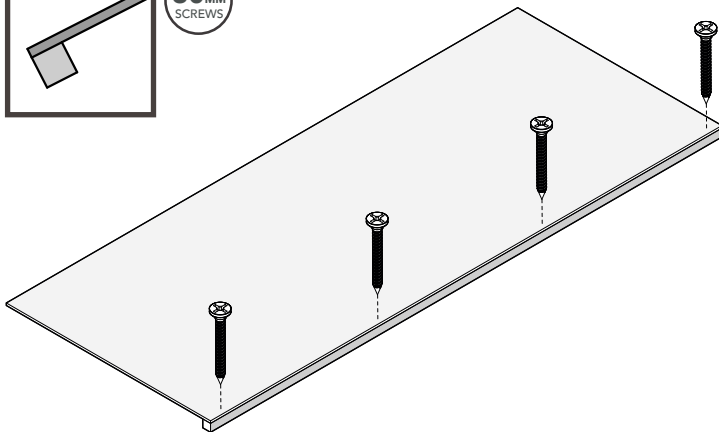

### OSB ROOF SHEETS & ROOF STRIPS

Position and secure the Roof Strip(s) along the edge of each OSB Roof Sheet as shown above. The Roof Strip(s) will be the same length as the OSB sheet edge. Ensure the Roof Strips are flush to the OSB Roof Sheet edge. Repeat the process for multiple sheets.

## STEP 2: SECURE ROOF SHEETS

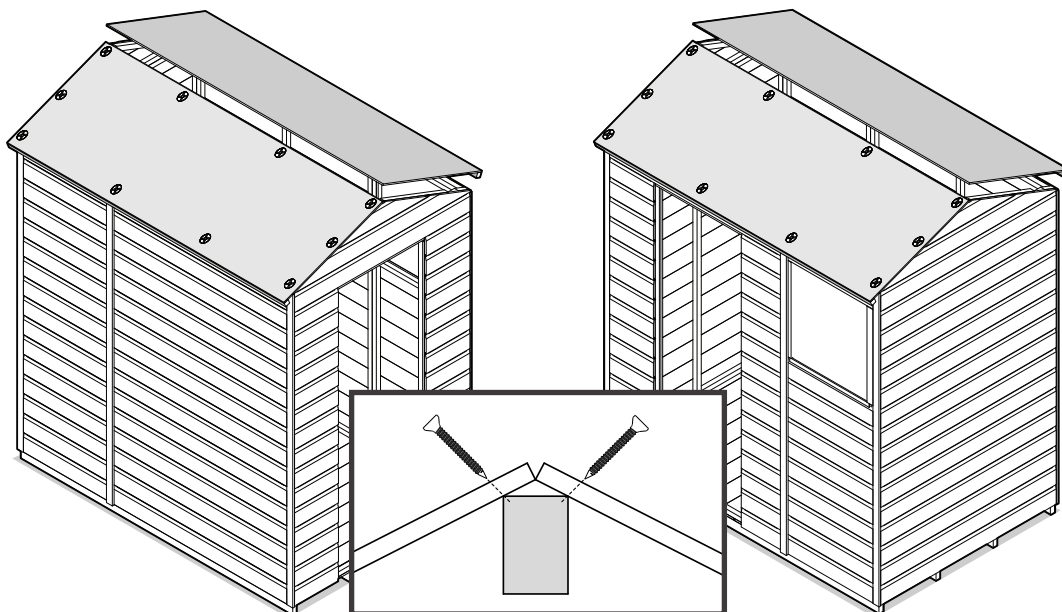

30MM  
SCREWS

### ROOF SHEETS

Position and secure the OSB Roof Sheets to the Apex Sections framework, Side Panels framework and the Ridge Beam.

## STEP 3: FELT

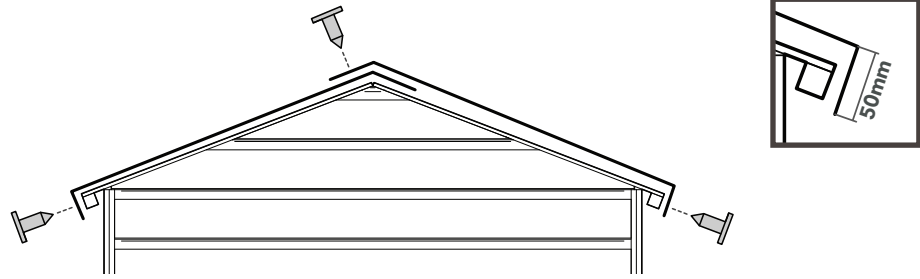

### 2 x FELT PIECES

Measure out 2 equal lengths and cut with a sharp knife. Overlap them on top, around the edges and fold the corners; tack to keep secure. Work from bottom to top ensuring there is a 50mm overhang at the bottom. Hammer the tacks into the felt at 150mm intervals.

# LEAN-TO LOG STORE

(PLEASE SKIP THIS SECTION IF YOUR SHED DOES NOT INCLUDE A LOG STORE)

## FIXING PACK CONTAINS:

FIXING PACK CODE: 4LIFELEANTOPF

You may receive more than one of the same fixing pack to provide enough screws and felt tacks for the larger shed sizes.

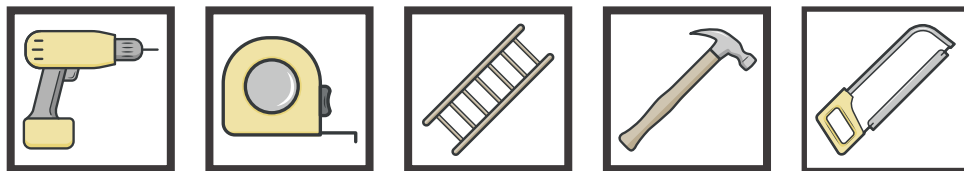
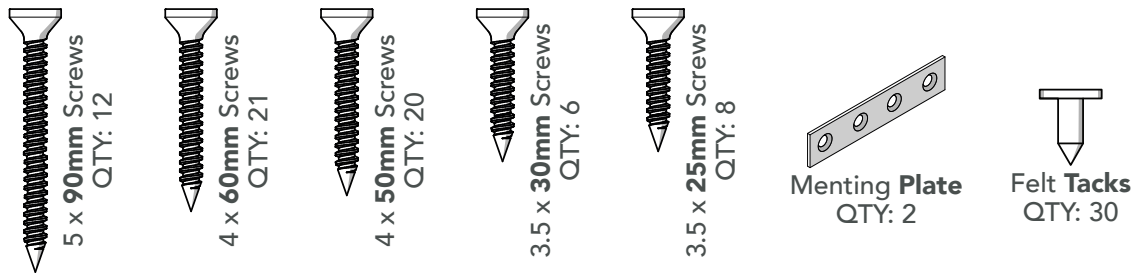

## STEP 1: MIDDLE COVER STRIP

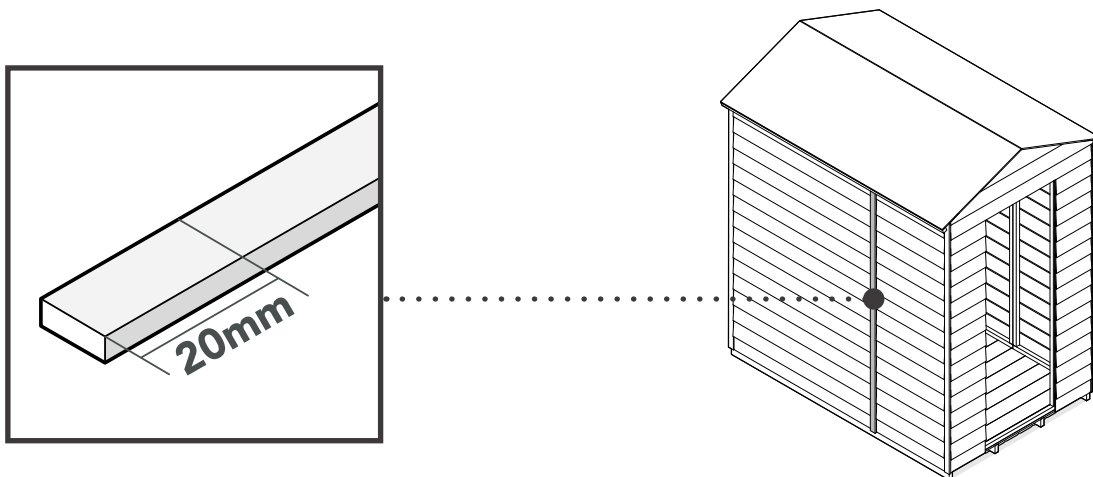

### RE-SIZE THE MIDDLE COVER STRIP

Detach the middle Cover Strip from the side you are attaching your log store. Using a hand saw, cut the middle Cover Strip down by 20mm from the bottom and re-attach back to its original position.

## STEP 2: FLOOR

4x6 SHED ONLY

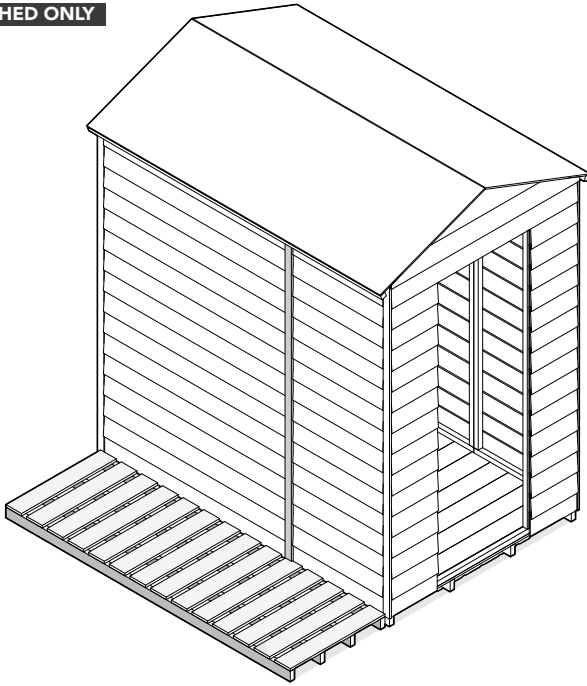

4x6 FLOOR

Position the Floor next to the shed. This will now be able to fit underneath the cut Cover Strip as shown above. (4x6 only has 1 x floor)

5x7 SHEDS

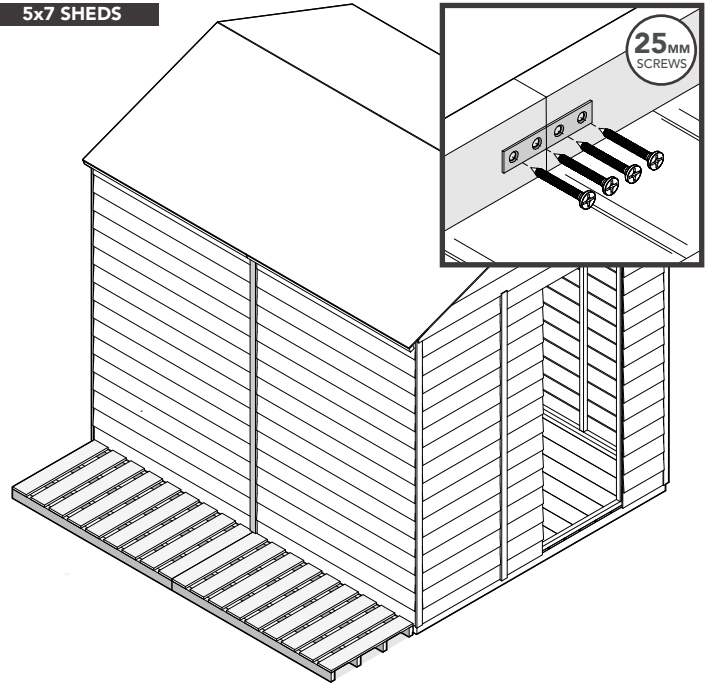

5x7 FLOOR

Turn the Floors upside down and connect them together using the mending plates. Position the Floor next to the shed. (5x7 has 2 x floors)

## STEP 3: SIDE PANEL PREPARATION

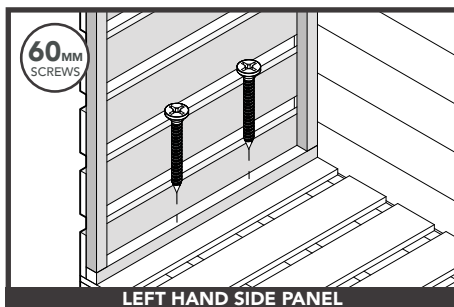

LEFT HAND SIDE PANEL

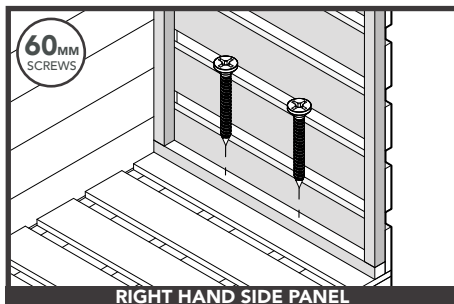

RIGHT HAND SIDE PANEL

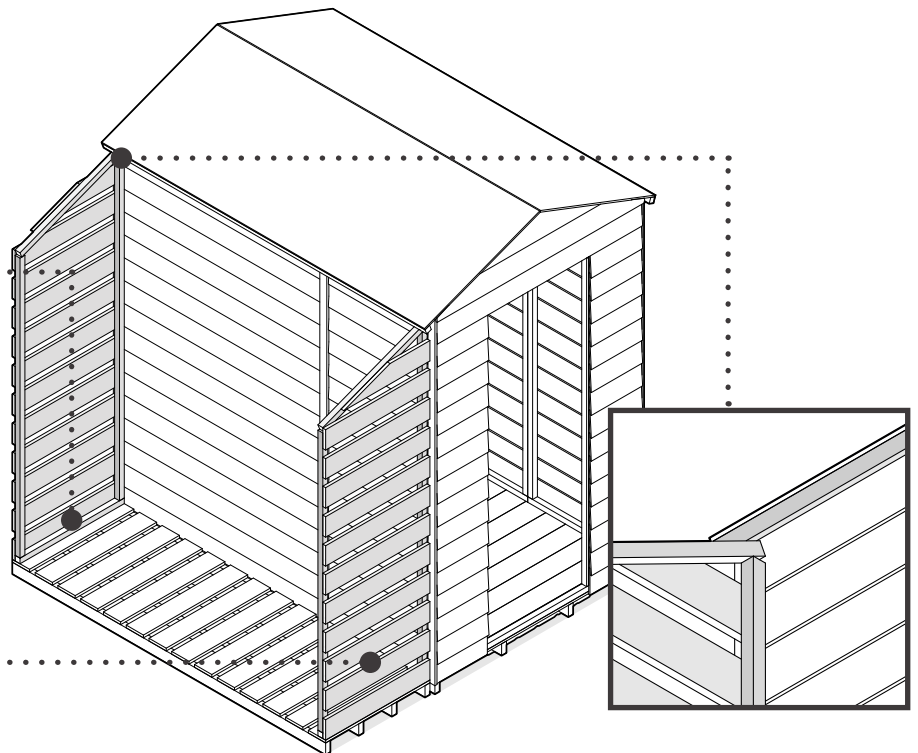

SIDE PANELS

Position and attach both of the Side Panels to the Floor. Ensure the panels are flush to the edge of the Floor and placed underneath the shed's roof batten.

# STEP 4: POSTS

4x6 SHED ONLY

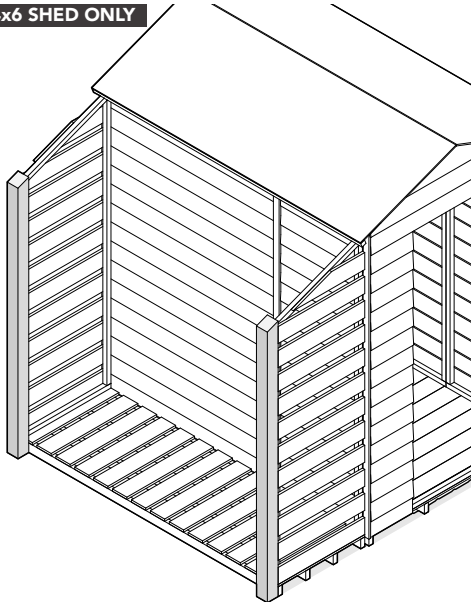

5x7 SHED ONLY

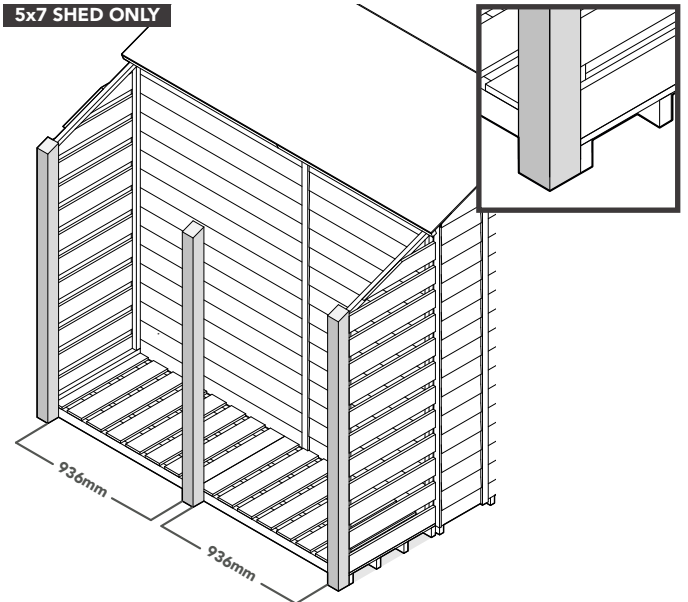

## POSITIONING THE POSTS

Position the Posts against the Floor(s) and ensure the Posts are flush to the Side Panels. Use the measurements provided to position the central Post.

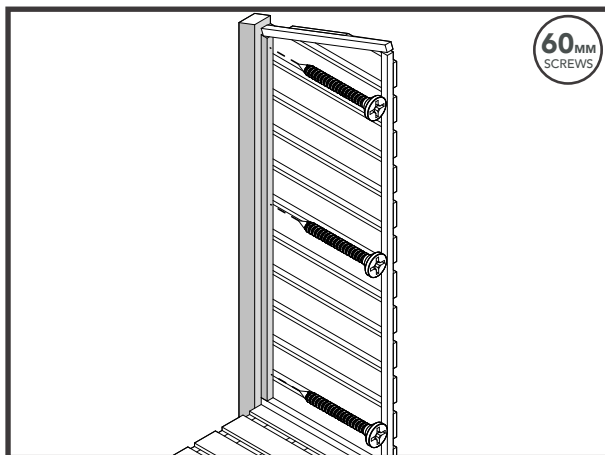

60mm  
SCREWS

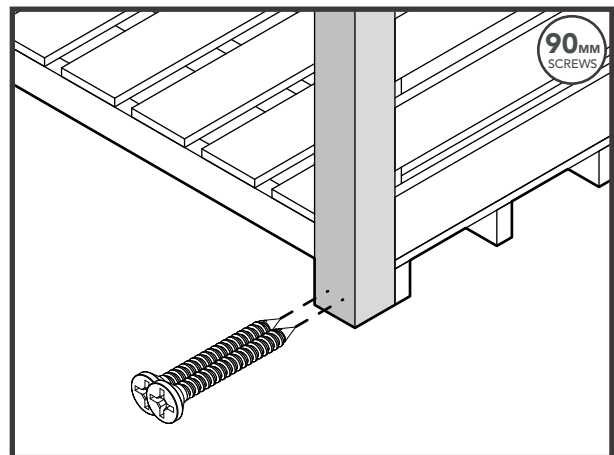

90mm  
SCREWS

4x6 SHED ONLY

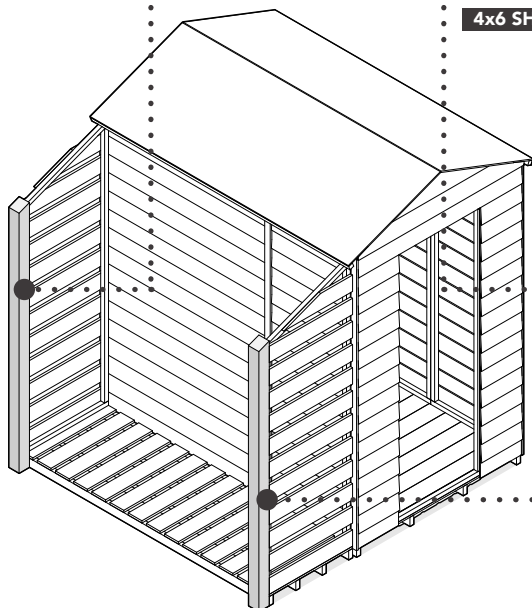

5x7 SHED ONLY

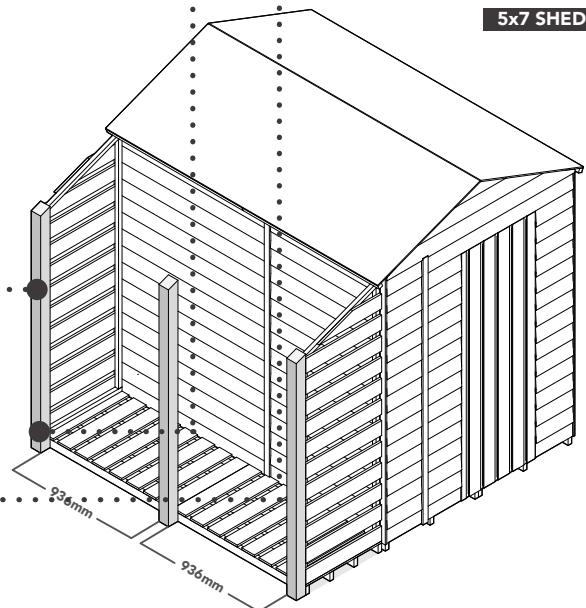

## SECURING THE POSTS

Secure the Posts to the floor bearers using 90mm screws. Secure the panels to the Posts using 60mm screws. Ensure the Posts are flush, and positioned using the measurements provided.

## STEP 5: ROOF

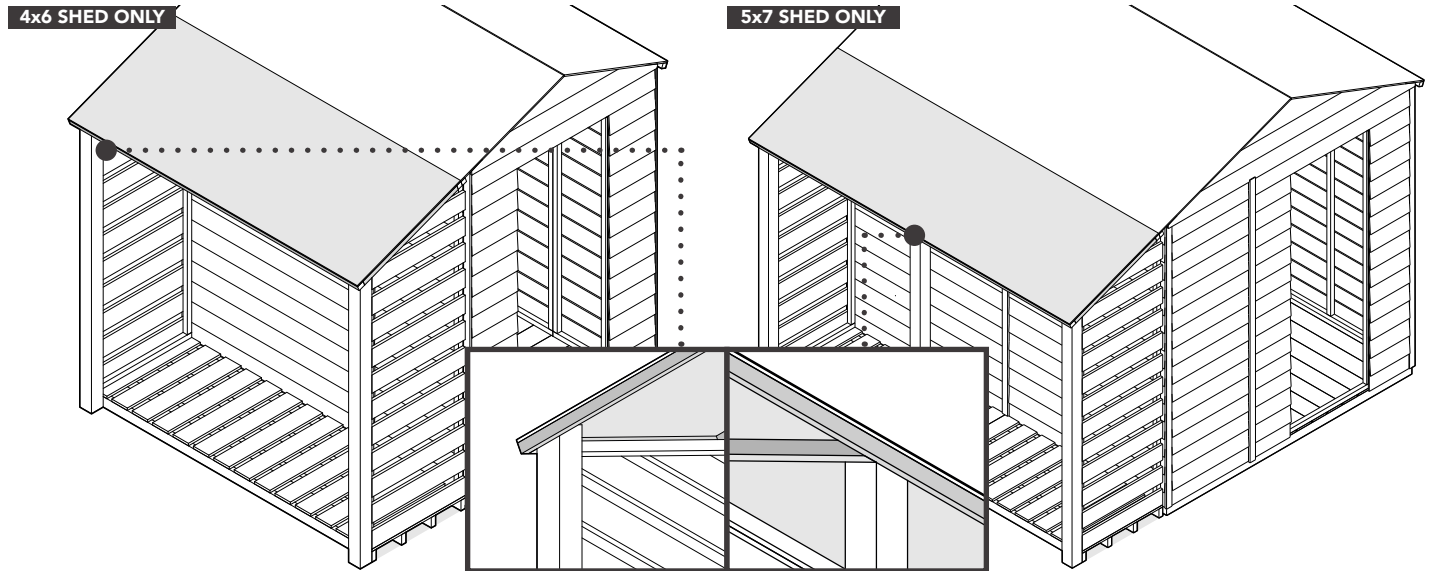

### POSITIONING THE ROOF

**Position the Roof.** Ensure the Roof is butt up to the shed's roof and the Posts sit inside the framework. If you have 3 x Posts, ensure the central Post is up against the middle batten attached to the Roof.

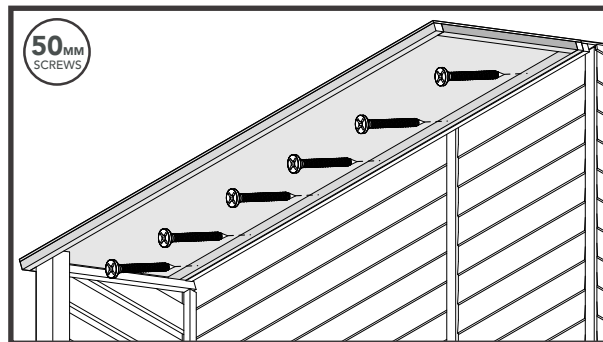

### SECURING THE ROOF

Secure the Roof to the shed's roof batten(s). Please take precautions when entering the log store to prevent any head injuries.

## STEP 6: SIDE PANELS

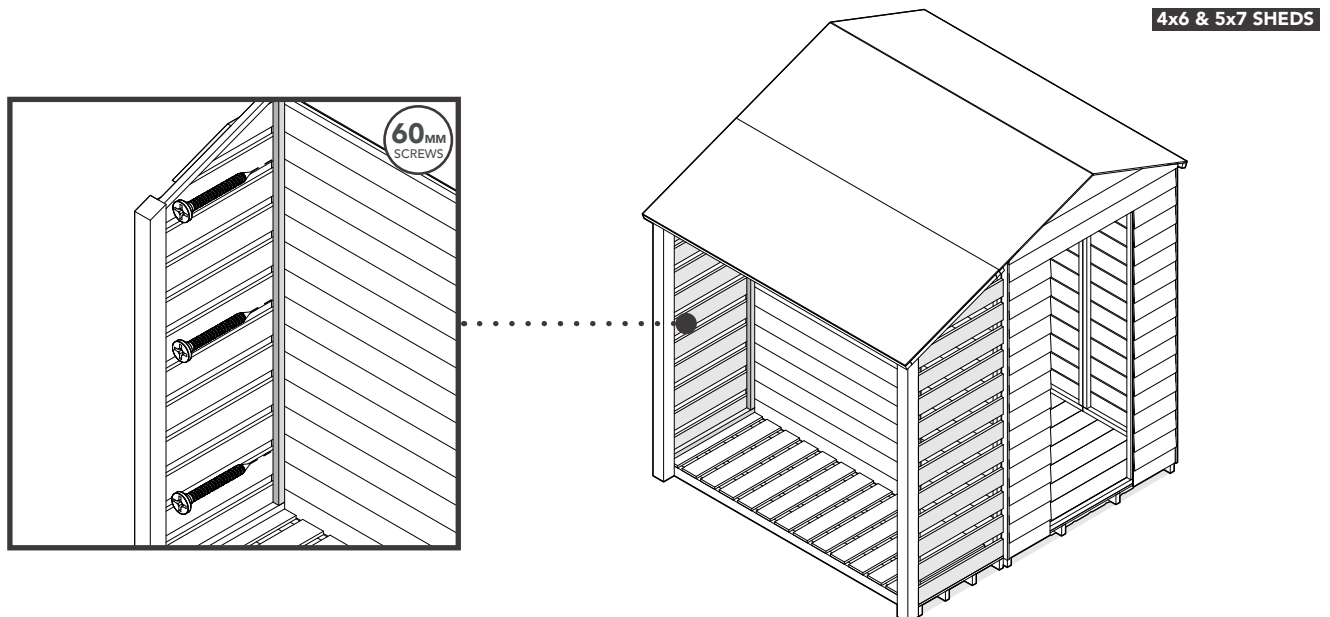

### SECURING SIDE PANELS

**Secure the Side Panels to the shed.** Ensure to screw through the overlap board to the framework behind, into the shed's framework using 60mm screws.

## STEP 7: ANGLED BRACES

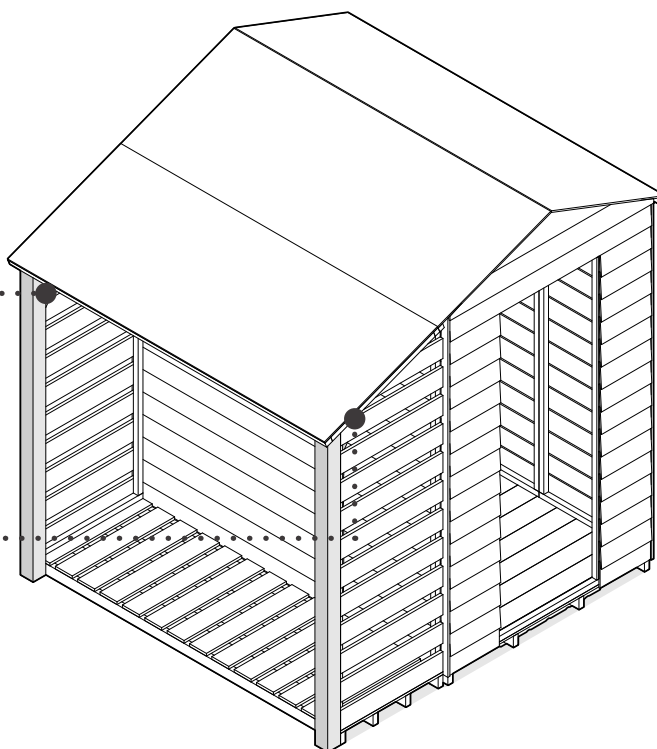
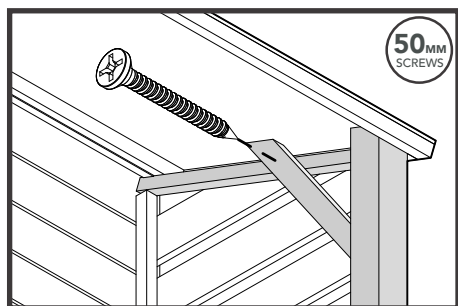
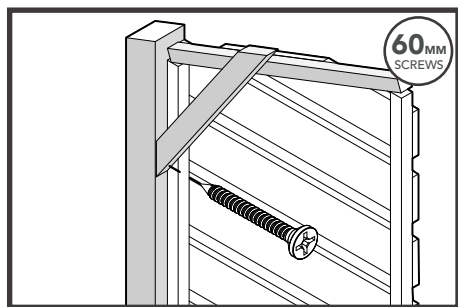

### SIDE ANGLED BRACES

Position and secure the Side Braces. Secure 1 x Side Brace to a Side Panel and Post as shown above.

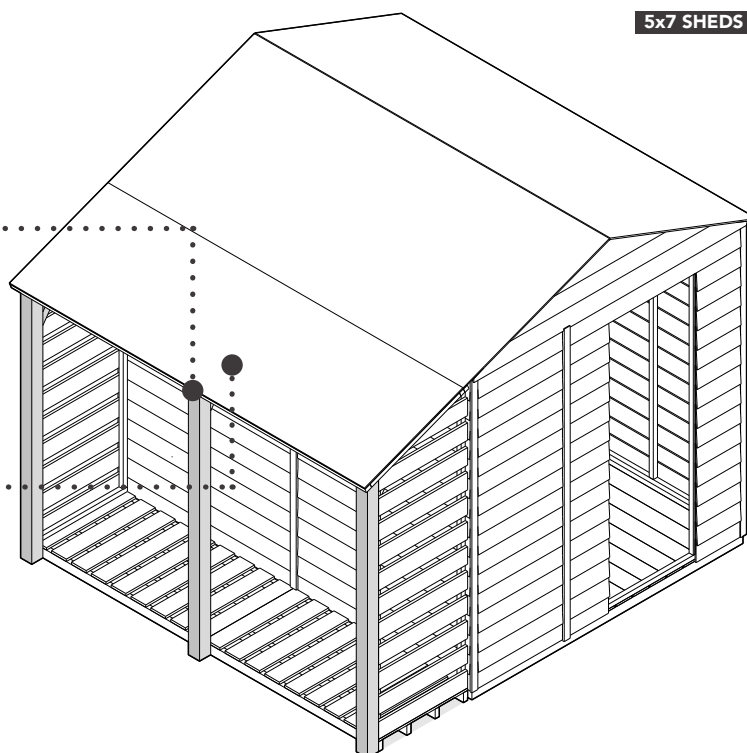
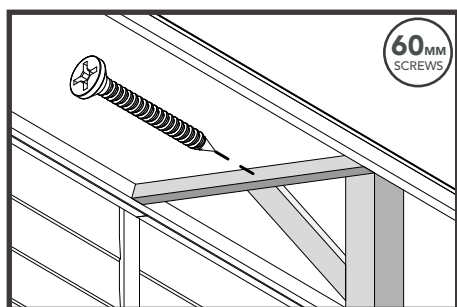
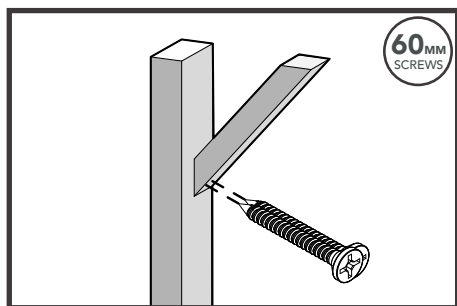

### MIDDLE ANGLED BRACES

Position and secure the Middle Brace to the Middle Post. Secure the central roof batten to the Middle Brace as shown above.

## STEP 8: SECURING THE ROOF

4x6 SHED ONLY

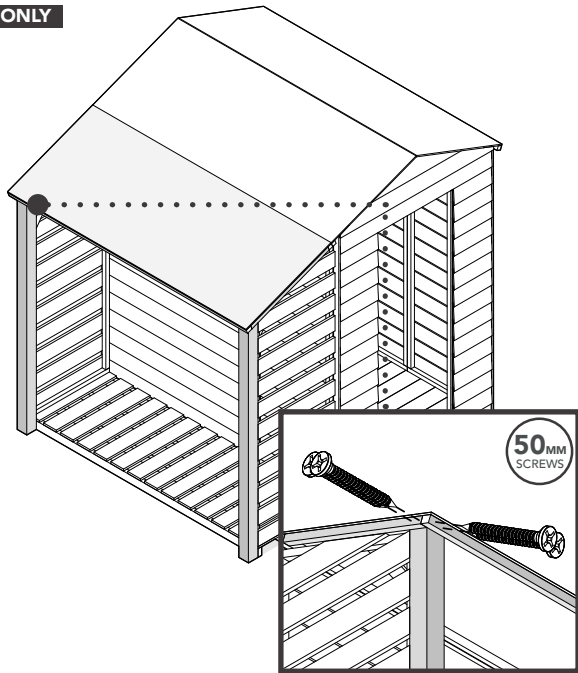

5x7 SHEDS

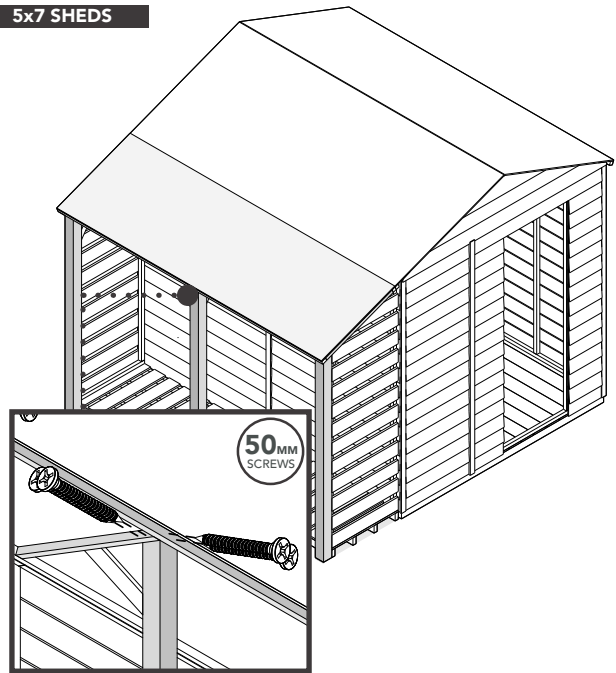

### SECURING THE ROOF

Secure the Roof to the side and central Post as shown above.

## STEP 9: FELT

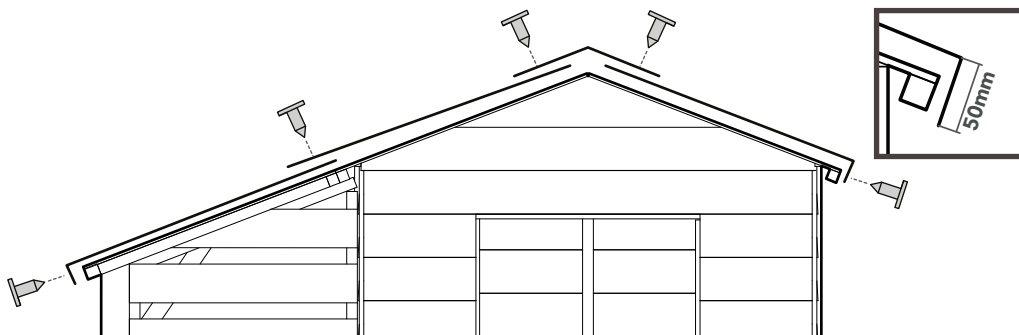

### FELT

Follow the main assembly instructions to begin felting your shed, and then continue down to felt your log store. Use a measuring tape to **measure out 3/4 equal lengths** & cut with a sharp knife. Hammer the tacks into the felt at **150mm intervals**.

## STEP 10: FASCIAS

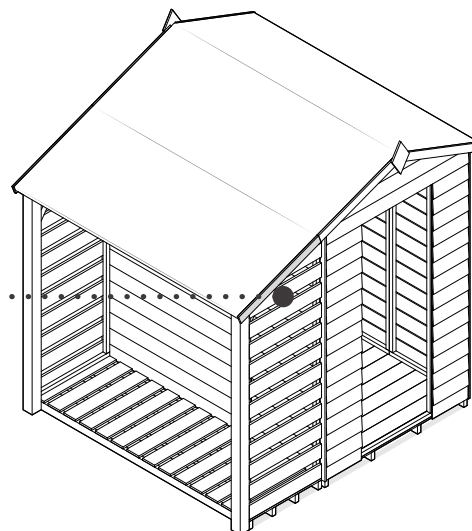
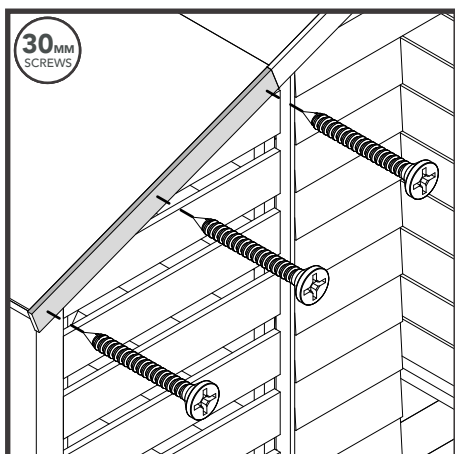

### FASCIAS

Position and secure the Fascia's to the log store once the sheds Fascia's have been attached.

# FASCIA'S & FINIALS

## FIXING PACK CONTAINS:

FIXING PACK CODE: 4LIFEFASCIASFP



4 x **40mm** Screws  
QTY: 16



3.5 x **25mm** Screws  
QTY: 4



1.6 x **25mm** Pin  
QTY: 2



4LIFE Shed **Badge**  
QTY: 1

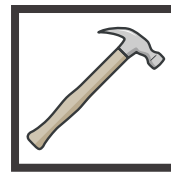
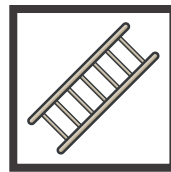
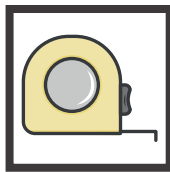
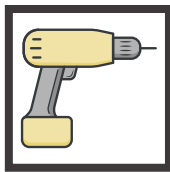

## STEP 1: FASCIA ASSEMBLY

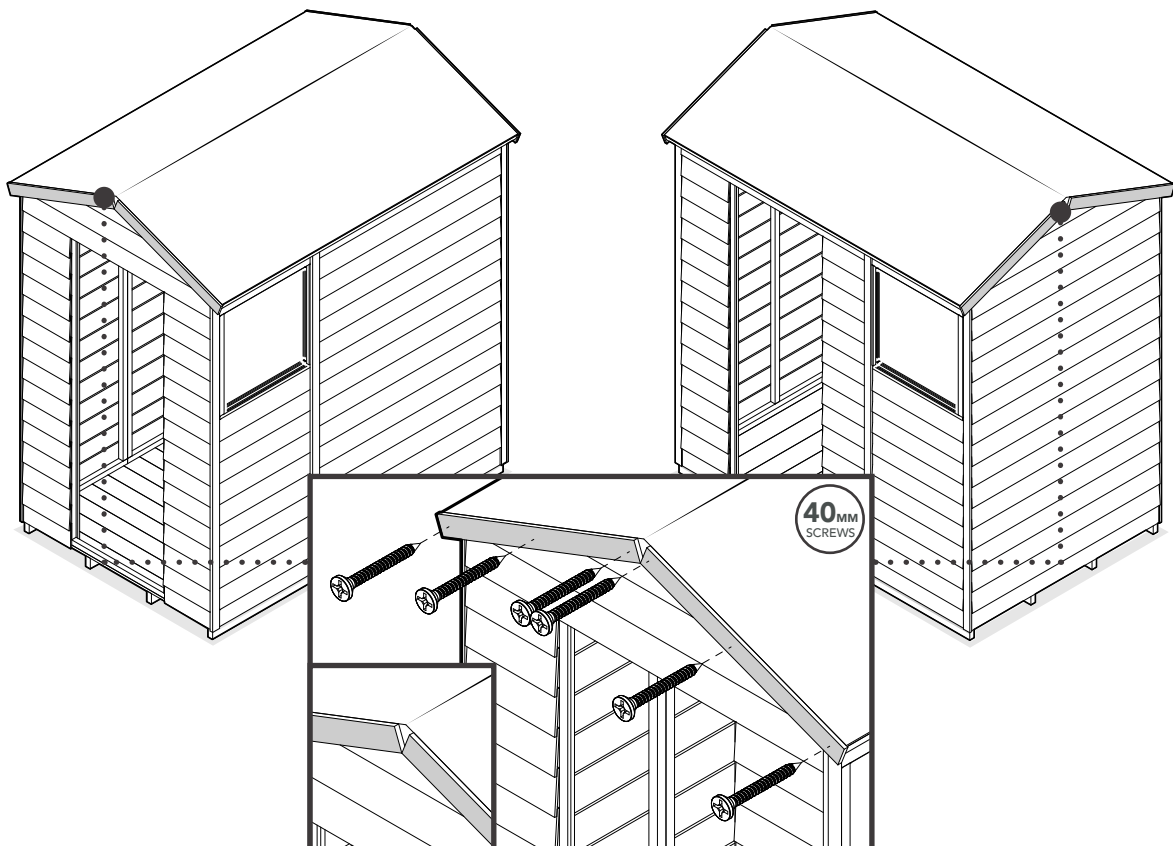

### APEX & REVERSE APEX FASCIA'S

Position and secure the Fascia's to the front and back or sides. The fascia's bottom edge will meet each other when positioning. Ensure to secure the Fascia's into the Apex Sections framework behind.



## STEP 2: FINIAL ASSEMBLY

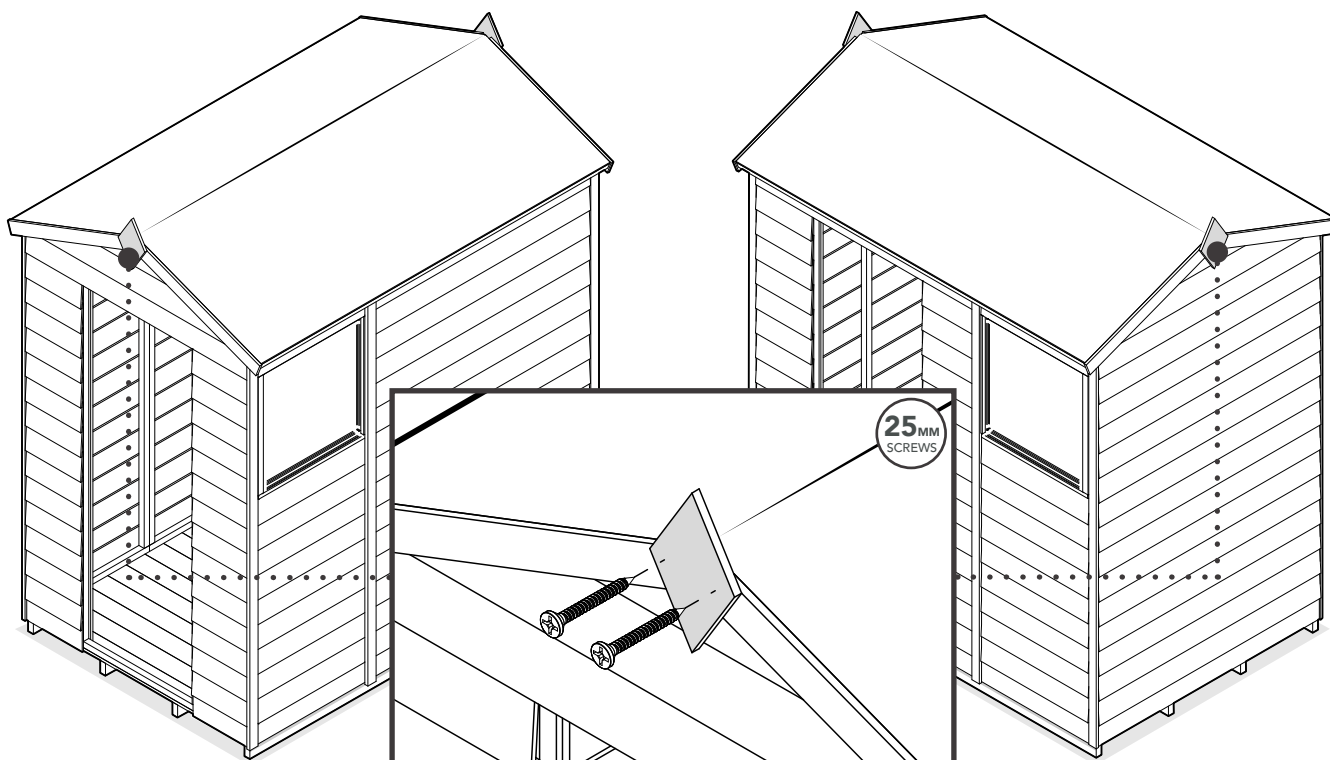

### FINIALS

Position and secure the Finials to the Fascia's as shown above. Ensure to secure through the Fascia's into the framework behind.

## STEP 3: BADGE

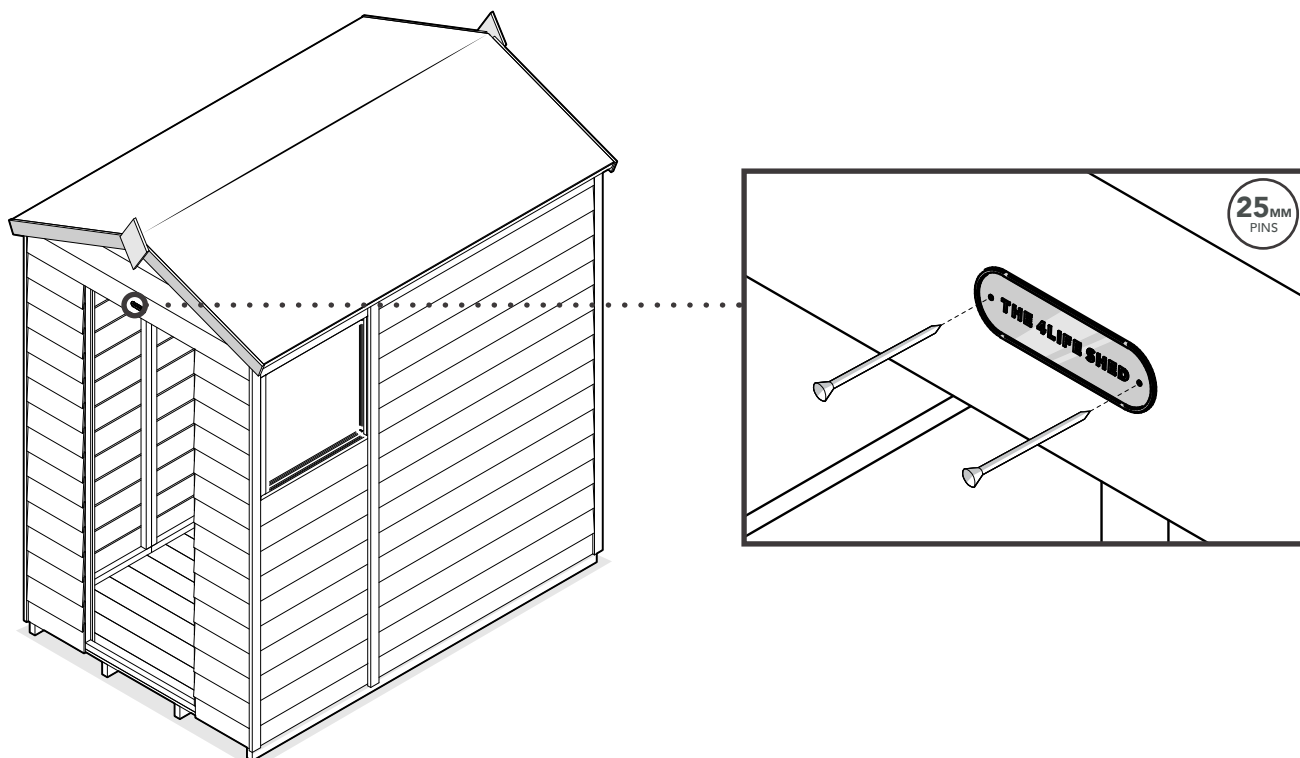

### PIN YOUR BADGE

Position and secure your badge above the door opening, into the Door Panel framework behind with the pins provided.

# SINGLE DOOR INSTALLATION

## FIXING PACK CONTAINS:

FIXING PACK CODE: 4LIFESINGLEDORFFP



3.5 x 25mm Screws  
QTY: 21

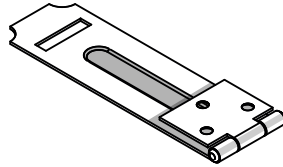

Hasp & Staple (150mm)  
QTY: 1



Turn Buttons  
QTY: 2

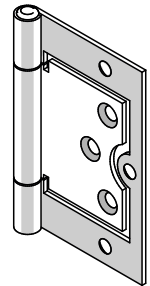

Flush Hinges  
QTY: 2

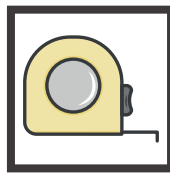
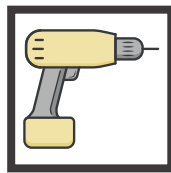

## STEP 1: DOOR HINGES & INSTALLATION

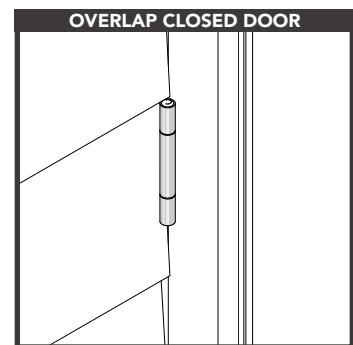
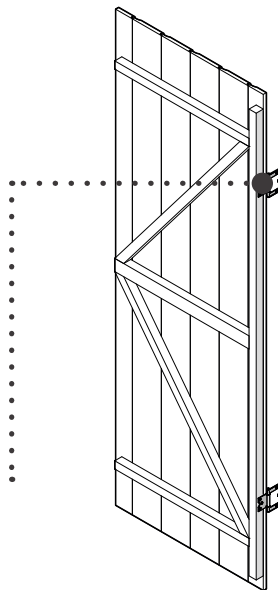
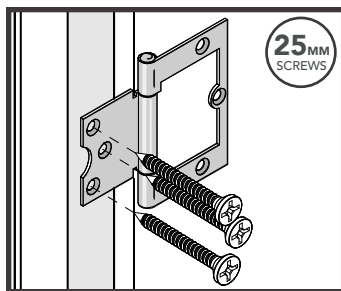
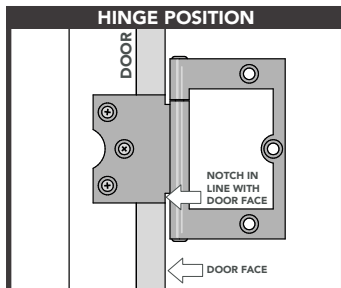

### DOOR HINGES

Position and secure 2 x hinges to the Door framework. Please take note of the hinge position. The hinges pin should sit under the overlap board and in the centre of the shiplap board as shown above.

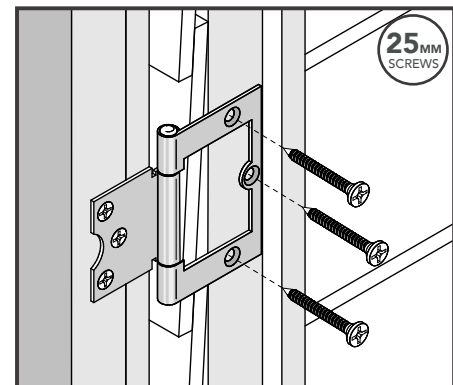
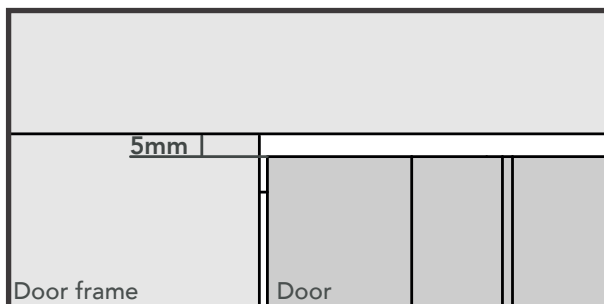

### DOOR INSTALLATION

Position the Door into the door opening, ensuring it is level. Ensure the hinges are up against the framework and on the side, you secured the Door Weather Strip. Secure the hinges in place. Allow a 5mm gap at the top when positioning the Door.

## STEP 2: DOOR FIXINGS

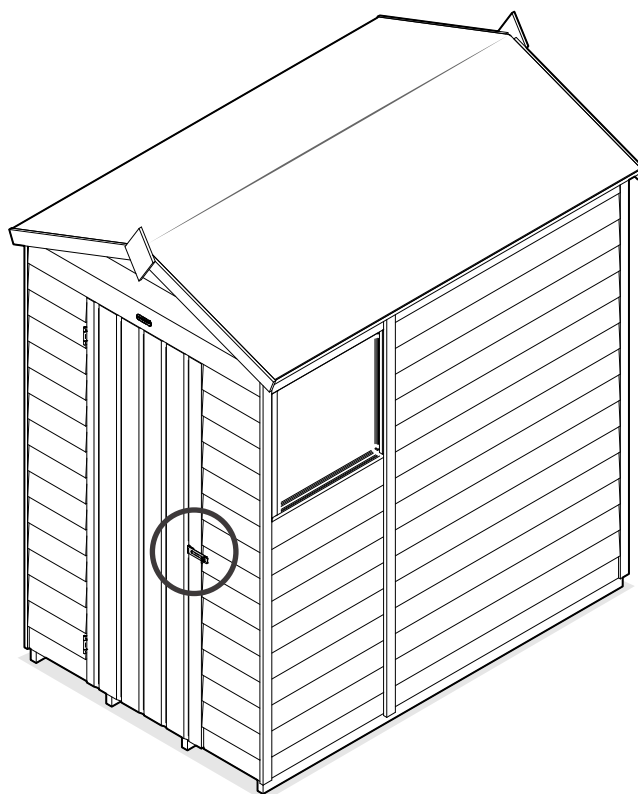
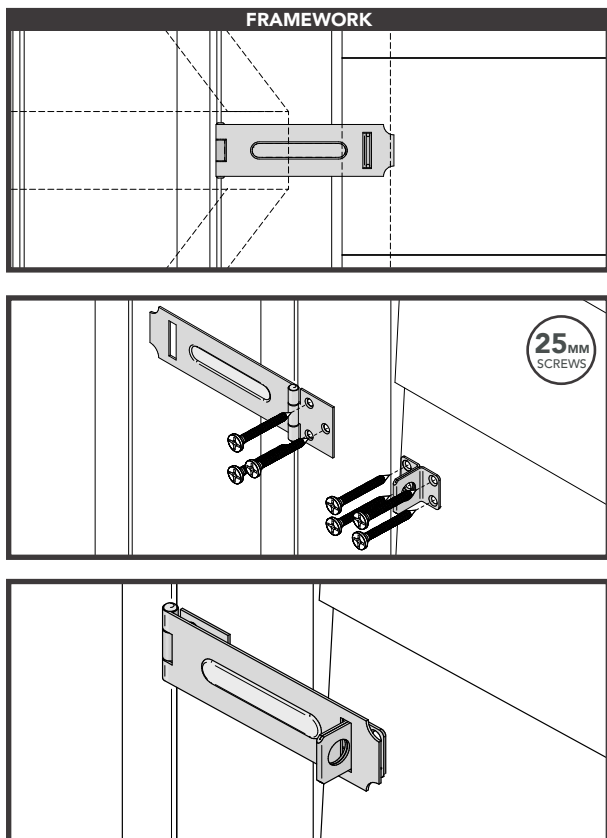

### HASP & STAPLE

Fix the Hasp and Staple as shown. Ensure the screws go into the framework behind.

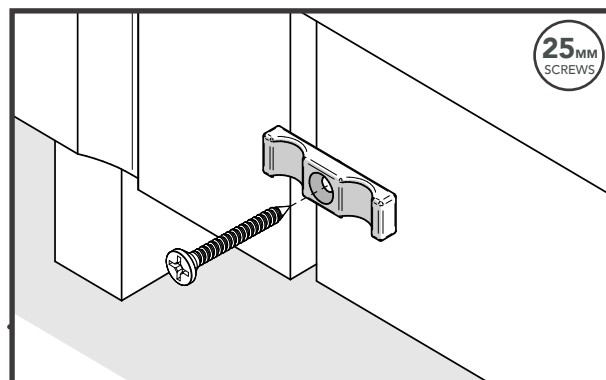
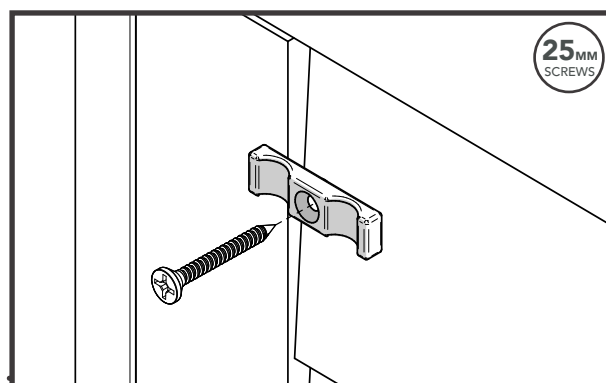
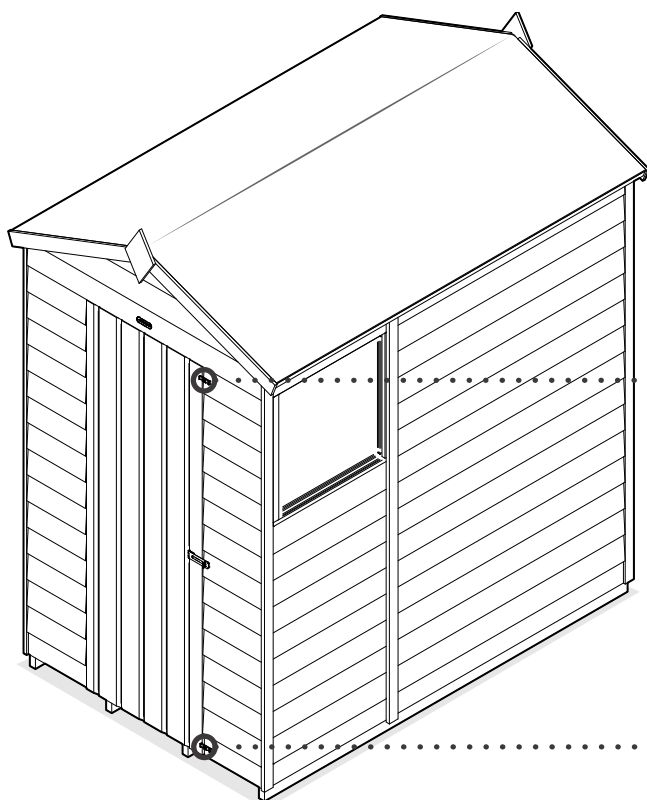

### TURN BUTTONS

Position and secure a turn button to the top and bottom of the Door Panel into the Door Panel's framework as shown above.